

QUANTUM H.E.

OWNERS'S MANUAL

Quantum H.E. SS9000

Quantum H.E. SS12000



*Whisper***KOOL**[™]
The Coolest Thing In Wine Storage

Conforms to ANSI/UL Std 427

Certified to CAN/CSA Std C22.2 No. 120

We manufacture, test and certify 100% of our wine cooling units in the USA. By sourcing the best components and closely controlling our manufacturing processes, we can assure the highest-quality, lowest defect manufacturing rates in the industry.

Copyright © 2012. WhisperKOOL. All rights reserved.

WhisperKOOL copyrights this manual, the product design, and the design concepts, with all rights reserved. Your rights with regard to the hardware and manual are subject to the restrictions and limitations imposed by the copyright laws of the USA. Under copyright laws, this manual may not be copied, reproduced, translated, transmitted, or reduced to any printed or electronic medium or to any machine-readable form, for any purpose, in whole or in part, without the written consent of WhisperKOOL.

Every effort has been made to ensure that the information in this manual is accurate. WhisperKOOL is not responsible for printing or clerical errors.

WhisperKOOL reserves the right to make corrections or improvements to the information provided and to the related hardware at any time, without notice.

Vinothèque and WhisperKOOL are registered trademarks, and ECE is a trademark of WhisperKOOL. All rights reserved.

Mention of third-party products is for informational purposes only and constitutes neither an endorsement nor a recommendation. WhisperKOOL assumes no liability with regard to the performance or use of these products.

Table Of Contents

Introduction.....	Page 2
Before You Start	Page 3
Preparing The Wine Cellar.....	Page 4
Receiving & Inspecting The System.....	Page 6
Quick Reference Guide.....	Page 7
Condensate Drain Pan.....	Page 8
Ducting Overview.....	Page 9
Rear Blower Orientation Instructions.....	Page 10
Top Blower Orientation Instructions.....	Page 13
Square To Round Plenum Installation.....	Page 18
Mounting The Evaporator Unit.....	Page 20
System Wiring And Connections.....	Page 21
24V Thermostat Kit Wiring Instructions.....	Page 22
Installing The Evaporator Unit.....	Page 23
Connecting The Line Set.....	Page 24
Drainage.....	Page 26
P-Trap Configuration.....	Page 28
Liquid-Measuring Thermostat System(Bottle Probe)-KDT.....	Page 29
Wall Mount Bracket Installation.....	Page 30
Flush Mount Bracket Installation.....	Page 33
Quantum Evaporator Wiring Diagram - KDT.....	Page 36
Quantum Evaporator Wiring Diagram - 24V.....	Page 37
Condensing Unit Wiring Diagram.....	Page 38
Line Set Piping Diagram.....	Page 39
Preparing The Condensing Unit.....	Page 40
Condensing Unit Wiring.....	Page 41
Installing The Condensing Unit.....	Page 42
System Operation - KDT.....	Page 47
System Operation - 24V.....	Page 48
Display Layout And Quantum 9000 Specifications.....	Page 49
Quantum 12000 Specifications.....	Page 50
Controller Functions	Page 51
Icon Glossary.....	Page 52
Alarm Codes.....	Page 53
User Menu.....	Page 54
Troubleshooting Guide.....	Page 55
Maintenance Schedule.....	Page 57
Adding Pan Tabs.....	Page 58
Cleaning P Trap.....	Page 58
Technical Assistance.....	Page 59
Warranty Information.....	Page 60
Warranty Registration.....	Page 65

INTRODUCTION

Customer Service

Thank you for purchasing a WhisperKOOL cooling system. We strive to provide the highest-quality products and the best possible customer service. If you have any questions about your system, please call us at 1-800-343-9463 or visit WhisperKOOL.com.

Using the Manual

This manual is intended to assist in the proper maintenance and installation of the cooling system. In order to ensure the longevity of your cooling unit, the equipment should be installed as outlined. It is also vital to establish a proper care and maintenance schedule. Please read and review this manual carefully and keep it for future reference.

What is the WhisperKOOL Cooling System?

The WhisperKOOL cooling system is a specialized refrigeration system designed for one purpose only: to maintain the optimal temperature and humidity levels conducive to the proper storage and aging of fine wines. This system produces minimal in-cellar noise and has the most lenient exhaust requirements.

How Does the Cooling System Work?

Similar to the air conditioning systems used for homes, the evaporator unit (fan coil unit) and condensing units are installed in separate locations and are connected by a refrigerant line set. The evaporator portion is commonly installed in the wine cellar, with the condensing unit is located either outside or in a remote indoor location that is properly ventilated.

Temperature Setting

The system is designed to maintain a cellar temperature of 55°F as long as the ambient temperature does not exceed 120°F.

BEFORE YOU START

1-800-343-9463

1. **Inspect the system before installation.** If damage is found, please contact your distributor or WhisperKOOL Customer Service at 1-800-343-9463.
2. The Quantum evaporator unit **requires a dedicated 120V, 15-amp circuit.**
3. The 9000 condensing unit **requires a dedicated 220V, 15-amp, single-phase circuit.** Use a surge protector with the unit. **Do not use a GFI outlet or breaker.**
4. The 12000 condensing unit **requires a dedicated 220V, 15-amp, single-phase circuit.** Use a surge protector with the unit. **Do not use a GFI outlet or breaker.**
5. 18-5 Communication cable is required between the evaporator and condensing units.
6. You are **REQUIRED** to **install a drain line** to remove condensation from the evaporator unit.
7. ***The warranty is not active until a warranty checklist has been received, reviewed, and approved.***
8. The system is intended **for use in properly designed and constructed wine cellars.** Hire a professional wine storage consultant with a valid contractor's license to build your wine cellar.
9. WhisperKOOL **requires that all split systems be installed by a certified HVAC-R technician only.** NATE or equivalent is recommended.

If you encounter a problem with your WhisperKOOL system, please refer to the Troubleshooting Guide. If you have any further questions or concerns, or need assistance, please contact WhisperKOOL's Customer Service at 1-800-343-9463. Please be sure all testing has been completed prior to contacting Customer Service. Please have your results ready for your representative.

PREPARING THE WINE CELLAR

The performance and life of your system is contingent upon the steps you take in preparing the wine cellar. Improperly preparing your enclosure or incorrectly installing your unit may cause unit failure, leaking of condensation, and other negative side effects.



It is highly recommended that you obtain the assistance of a wine storage professional.

Wine storage professionals work with licensed contractors, refrigeration technicians, and racking companies to build well-insulated, beautiful, and protective wine cellars. We have put together some useful tips to assist in the installation process. Our recommendations are meant to act as a guide in the process of building a proper enclosure. Your intended location may have specific needs which we do not address.

Wall & Ceiling Framing

Build wine cellar walls using standard 2x4 or 2x6 boards and ceiling joists without violating local or state codes in your area. As a general rule, the thicker the walls and the higher the insulation value, the more consistent your cellar temperature will be.

Insulation

Insulation is **REQUIRED** in order to properly use our products. It is vital that all walls and ceilings be insulated to keep the cellar temperature as consistent as possible during the summer and winter months. Standard fiberglass or rigid foam insulation is normally used in cellar construction; in some cases, "blown-in" insulation is used. The R-value, or quality of insulation, is determined by the rate at which heat passes through the insulation. The higher the R-value, the more resistant the insulation is to conducting heat, and the more consistent your wine cellar's temperature will be. Using higher R-values in insulation will lower your operating costs and unit run time. (R-13 is the recommended minimum; R-19 is preferred for interior cellar walls, and R-30 for ceilings and exterior walls.)

Vapor Barrier

Water vapor creates its own pressure, separate from the ambient air pressure, and will intrude into colder/drier areas. A vapor barrier is **REQUIRED** in order to prevent the intrusion of water vapor and maintain the correct cellar temperature and humidity. It is recommended that 6-millimeter plastic sheeting be applied to the warm side of the cellar walls. The vapor barrier must also be applied to the outside walls and ceiling. If it is impossible to reach the outside, then the plastic must be applied from within the cellar. The most common method is to wrap the entire interior, leaving the plastic loose in the stud cavity so the insulation can be placed between each stud. All of the walls and ceiling must be wrapped in plastic for a complete vapor barrier.

In areas of high humidity, such as Southern and Gulf States, the vapor barrier will prevent infiltration of warm moist air. The moist air can cause mold to form, and standing water in drain pans promote microbial and fungal growth that cause unpleasant odors and indoor air quality problems. If mold is found, remove it immediately and sanitize that portion of the unit.

Note: High humidity significantly increases the heat load on the cooling system.

Any break in the vapor barriers (cut, nail hole, over-lapping, etc.) will cause a moisture leak and must be sealed. The electric conduit is a "duct" for vapor to travel in. The conduit should be caulked and sealed on the warm air end.

PREPARING THE WINE CELLAR, CONTINUED



Unobstructed Airflow

Unobstructed airflow to and from the system is critical for the evaporator unit and condensing units overall performance and lifespan. A minimum of 3 feet of clearance (5 feet is ideal) on all sides is crucial. The air the fans blow needs to circulate and either dissipate or absorb heat from the space. The more air to exchange, the more efficient the system will operate.

Note: Avoid attempting to camouflage the unit. This will restrict airflow and thus the systems ability to work efficiently.

Door and Door Seal

An exterior grade (1¾") door must be installed as a cellar door. It is essential that weather stripping is attached to all 4 sides of the doorjamb. A bottom "sweep" or threshold is also required. The door must have a very good vapor seal to prevent warmer moist air from leaking into the cellar. One of the most common problems with cooling systems running continually is due to the door not sealing properly. **In cases where glass doors are used and the room size is close to the recommended system size, the next larger size system should be used.** This will compensate for the insulation loss due to the lower insulating rating of glass.

Ventilation

The necessity of dissipating heat away from the condensing unit is critical to the unit's performance and cannot be overstated. As the system operates and cools, a greater amount of heat is generated on the condensing side of the system. Adequate ventilation is required in order to dissipate heat away from the condensing unit. If ventilation is inadequate, the exhaust will heat up the area or room and adversely affect the system's ability to cool. Avoid installing the condenser in a closet or other small rooms and spaces. This will cause the system to overheat and void the warranty.

Note: If you are unsure about having adequate ventilation in your install location, please contact us to assess your specific installation

Ambient Temperature Factor

The cooling system has the ability to cool a wine cellar efficiently to 55°F as long as the ambient temperature of the area that it is exhausting to does not exceed 120°F. Therefore, you want to exhaust the condensing unit in a space which will not exceed 120°F. Otherwise the system will not have the capacity to keep the wine at a desirable 55°F.



WARNING! Allowing your system to operate in temperatures of 120° or above for extended periods of time will greatly decrease the life of your system and void your warranty. The cooler the temperature of the air entering the condenser coil, the more cooling capacity the system has. The less heat gain through the common wall, the less the electricity consumption.



RECEIVING & INSPECTING THE SYSTEM

Upon receiving your WhisperKOOL unit:

NOTE: WhisperKOOL units are manufactured in the USA and tested prior to shipment.

- ☞ Use caution when lifting and check the package for damage.
- ☞ Lift only at the designated hand-hold locations on the shipping container, or fully support the unit from underneath. A shipment may include one or more boxes containing accessories.
- ☞ Inspect the packaging for any obvious signs of damage or mishandling before opening the container.
- ☞ Note any discrepancies or visual damage on the bill of lading before signing.
- ☞ Sit unit upright for 24 hours.
- ☞ Review the packing slip to verify contents.
- ☞ Check the model number to ensure it is correct.
- ☞ Check that all factory options ordered are listed.

If any items listed on the packing slip do not match your order information, contact WhisperKOOL Customer Service immediately.

Verify that the pallet you've received contains the following:

- (1) Evaporator box
- (1) Square-to-round plenum box
- (1) Condensing unit box

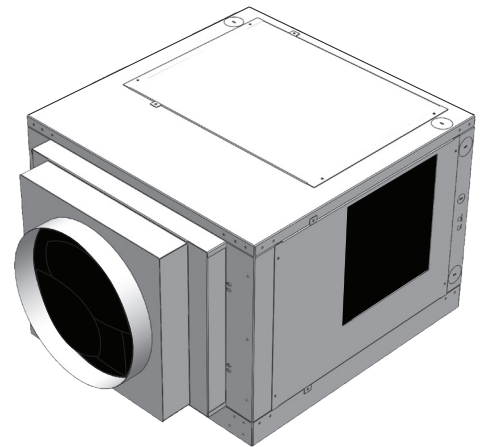

Pictured: Quantum evaporator unit

1. Verify that the evaporator unit (fan coil unit) box contains the following:

- ☞ (1) Quantum evaporator unit
- ☞ (1) Foam fan bracket
- ☞ (2) Rubber grommets (13/32")
- ☞ Strip of cork tape (1")
- ☞ (2) 1/2" nylon plugs
- ☞ (1) Flush mount template
- ☞ (18) Antimicrobial pan tabs
- ☞ (1) Drain line brush
- ☞ 6-1 3/4" PVC male adapter

Accessory kit bag:

KDT unit only

- ☞ Flush mount template
- ☞ KDT Plus display cable (50 feet)
- ☞ KDT Plus wall mount bracket assembly
- ☞ KDT Plus flush mount bracket assembly
- ☞ KDT Plus display assembly
- ☞ KDT Plus Hardware bag

- ☞ (1) 1 1/16" OD Grommet
- ☞ (2) 1/2" nylon hole plugs
- ☞ (4) #6 x 1" PHP zinc Type A screws
- ☞ (4) 8-10 x 7/8" Plastic Screw Anchor

Documentation bag:

- ☞ Quantum H.E. owner's manual
- ☞ R-134a H.E. split system warranty checklist

2. Verify that the condensing unit box contains the following:

- ☞ (1) Quantum SS9000 H.E. condensing unit OR
- ☞ (1) Quantum SS12000 H.E. condensing unit (depending on unit ordered)

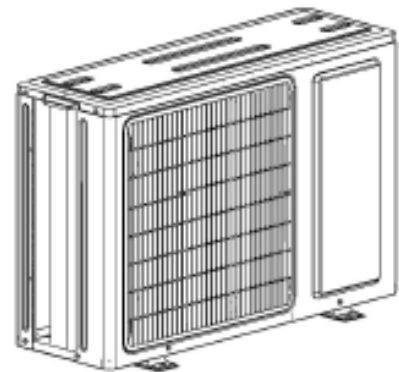

Pictured: SS9000 condensing unit

3. Verify that the square-to-round plenum box contains the following:

- ☞ (1) Square-to-round plenum
- ☞ (8) #10-16 x 1/2" steel drilling screws

Please leave the unit in its original box until you are ready for installation. This will allow you to move the product safely without damaging it. When you are ready to remove the product from the box, refer to the installation instructions.

TIP: Save your box and all packaging materials. They provide the only safe means of transporting/shipping the unit.

QUICK REFERENCE GUIDE

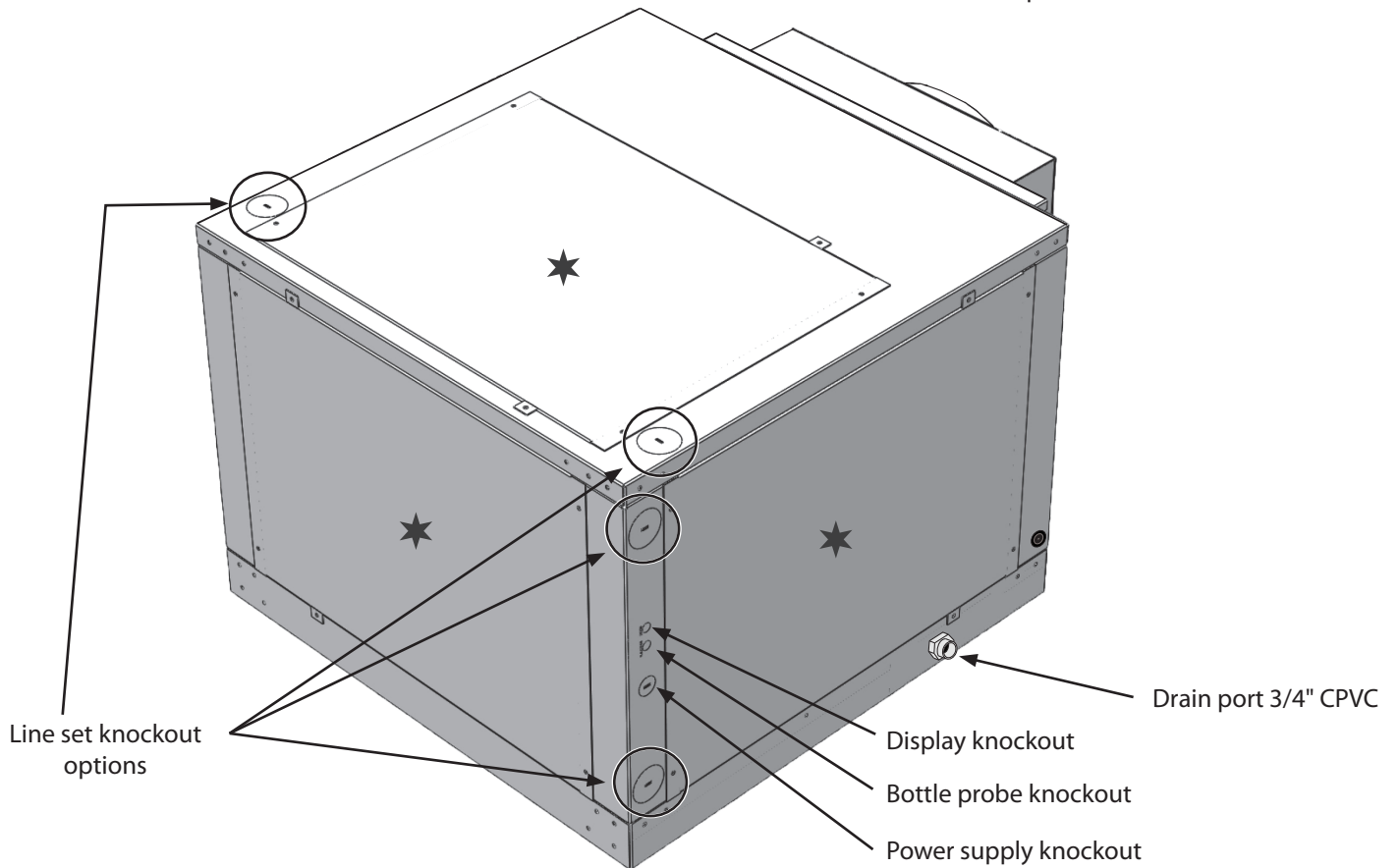
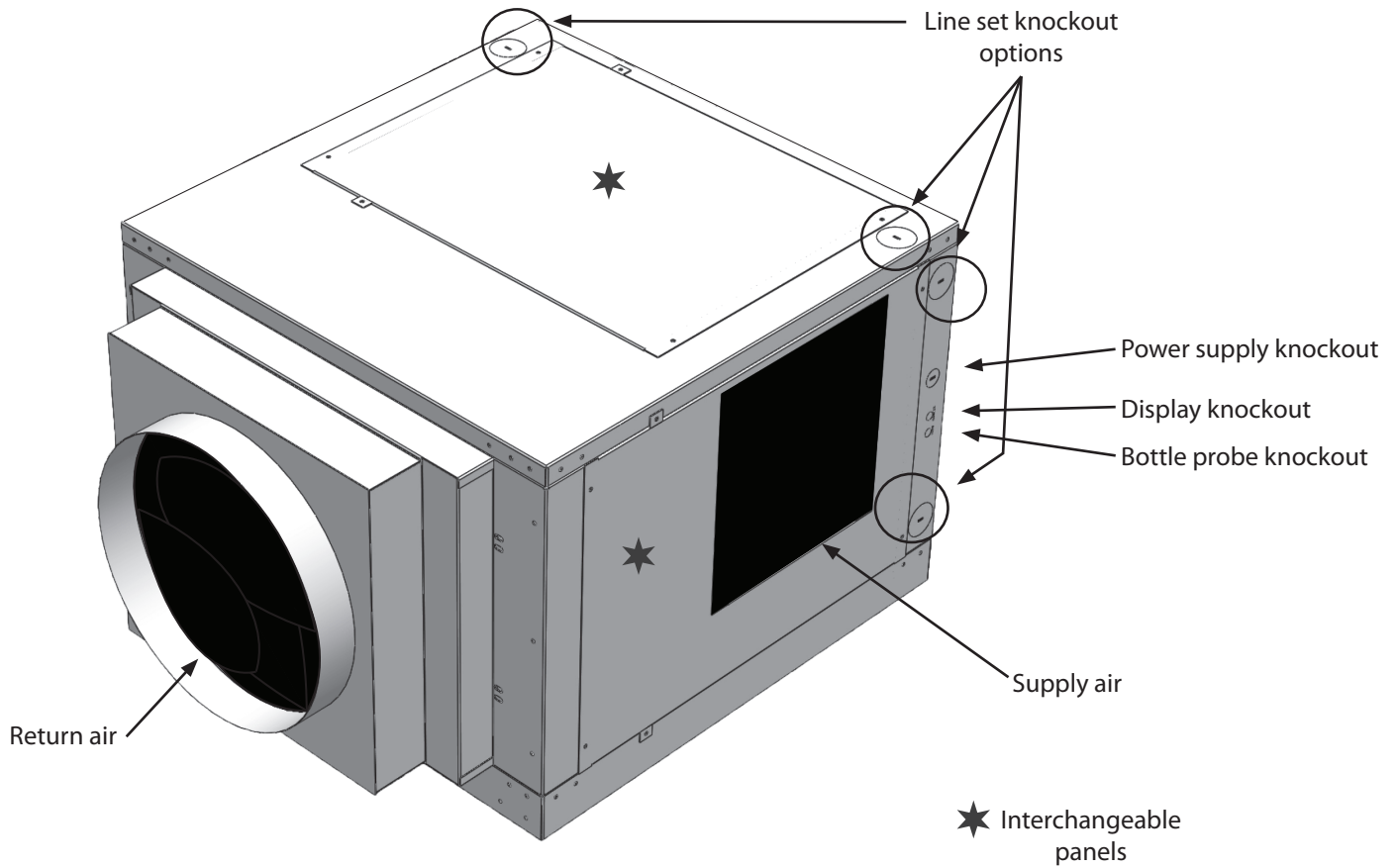

CONDENSATE DRAIN PAN

Check local codes and regulations regarding the disposal of condensation for specific installation requirements. A separate drain line will need to be installed. Please see page 26 for more info.

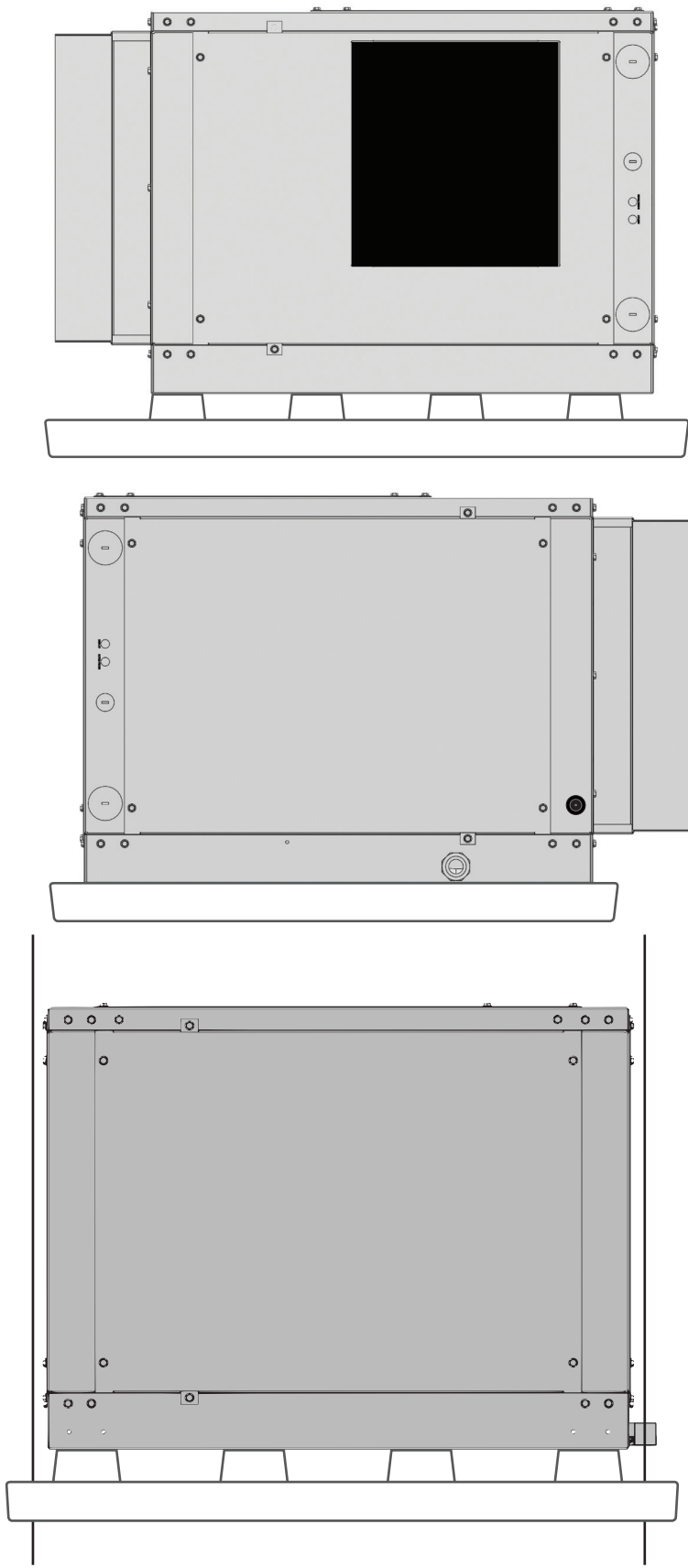

DUCTING OVERVIEW

Use ductwork to connect the unit to the supply and return outlets in the wine cellar. Use only insulated ductwork to minimize cooling losses, prevent sweating, and reduce noise. Use ductwork on the condenser section to redirect or absorb sound, bring in outside air to the unit inlet, and/or exhaust the hot air.

Note: Do not exceed a total of 25 feet for each length of ductwork run and a combined total of 50 feet for both the supply and return lengths.

Avoid crimping the flexible ducts. This reduces airflow, causing the unit to operate improperly. Be sure all ductwork and outer surfaces in contact with the airflow are insulated and have a vapor barrier on the outside. Uninsulated supply and return ducts may cause bare, exposed metal surfaces to sweat, further degrading the insulation and equipment cooling capacity.



Do not allow sharp turns to squeeze or decrease the inside diameter of the flexible ducting.



General duct recommendations:

- Provide support for the flexible duct to prevent sags and bends.
- Quantum 9000 and 12000 duct size: 14" supply and return
- Register size: 14" x 14"
- Filter size: 14" x 14" (MERV 4)
- Stretch out the duct to make a smoother interior which reduces air resistance.
- Maximum duct length is 25 feet.
- For 90° bends, use a 90° adjustable elbow.
- No more than two 90° bends on each duct. Sweep 90° bends are recommended rather than sharp 90° bends.
- Generously apply duct sealant to all metal seams to fill in gaps that can leak air. Allow sealant to dry until firm to the touch before applying fiberglass insulation.
- Do not squeeze or reduce the inside diameter of the ducts, as this will reduce airflow.
- Use short and straight ductwork where possible.
- Check that all fan blades move freely.
- Keep air paths free of loose foreign objects and debris.
- Locate the supply and return grilles inside the cellar to create an airflow pattern that maximizes air circulation in the room. Avoid short circulation of the air.

DO NOT:

- Install through-the-wall return air grilles at floor level where they will collect dust from the floor.
- Locate the supply or return air grille where it is blocked by bottles, boxes, or cases.

REAR BLOWER ORIENTATION INSTRUCTIONS

1. The Quantum evaporator unit is shipped with the blower and supply panel oriented to the right. If this is your desired orientation, proceed to the installation instructions on page 23.
2. To reorient the blower, first remove the access panels on the rear and top of the unit.

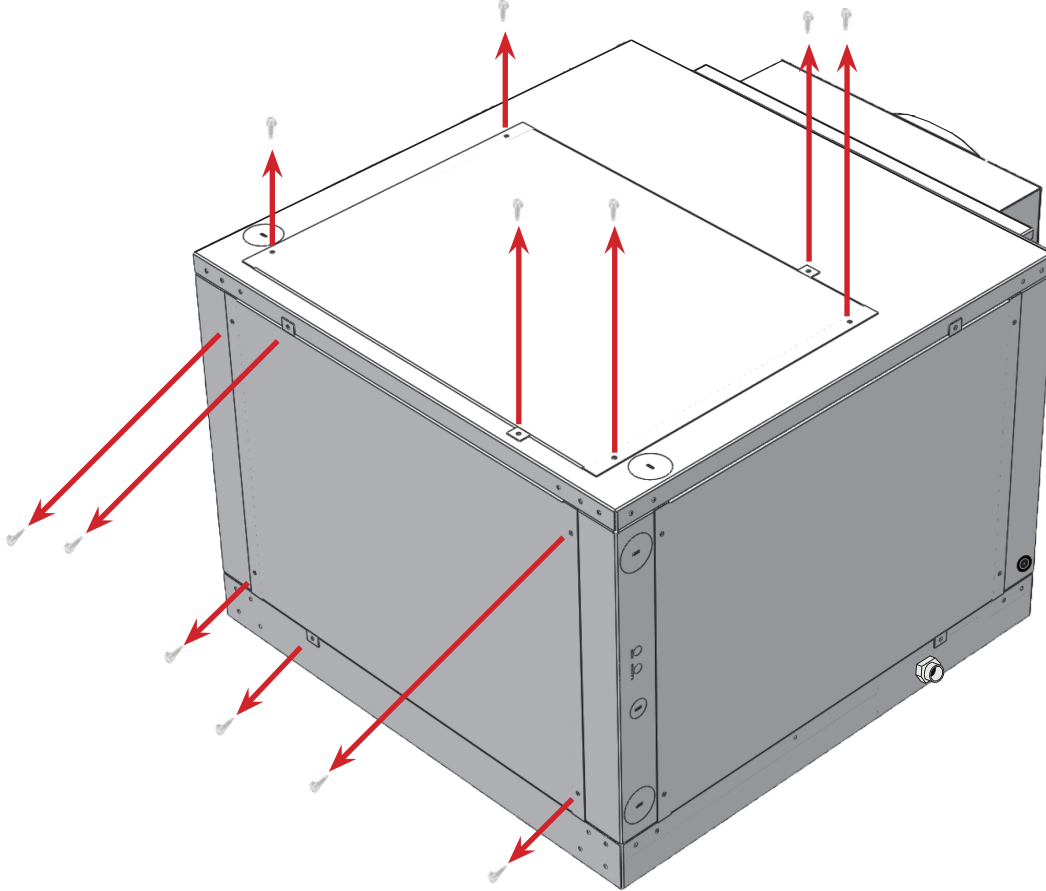

3. Next, remove the eight (8) screws securing the blower to the supply panel.

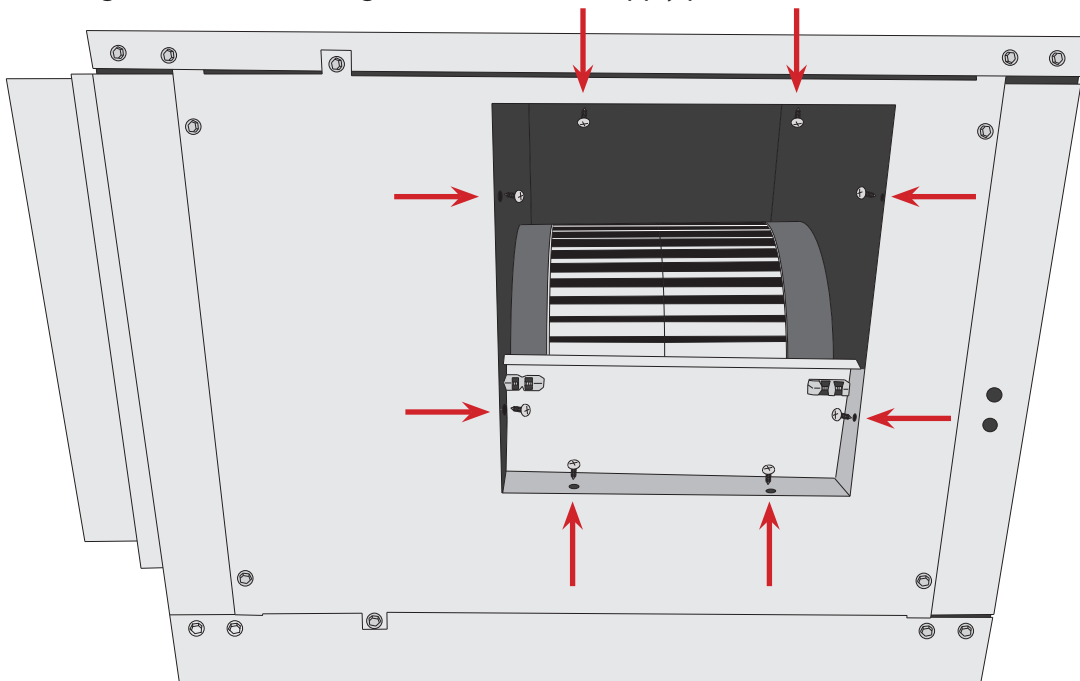

REAR BLOWER ORIENTATION INSTRUCTIONS, CONTINUED

4. Remove the six (6) screws securing the supply panel to the unit housing.

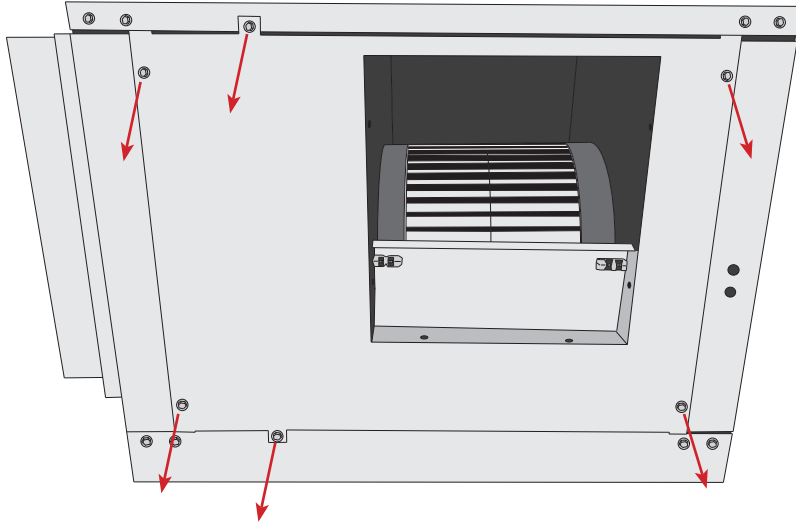

5. Remove the supply panel.

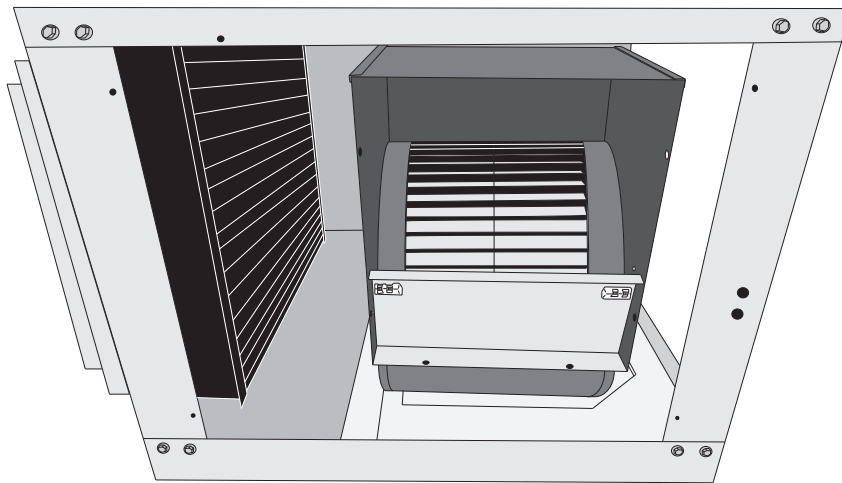

6. Rotate the blower to the rear configuration.

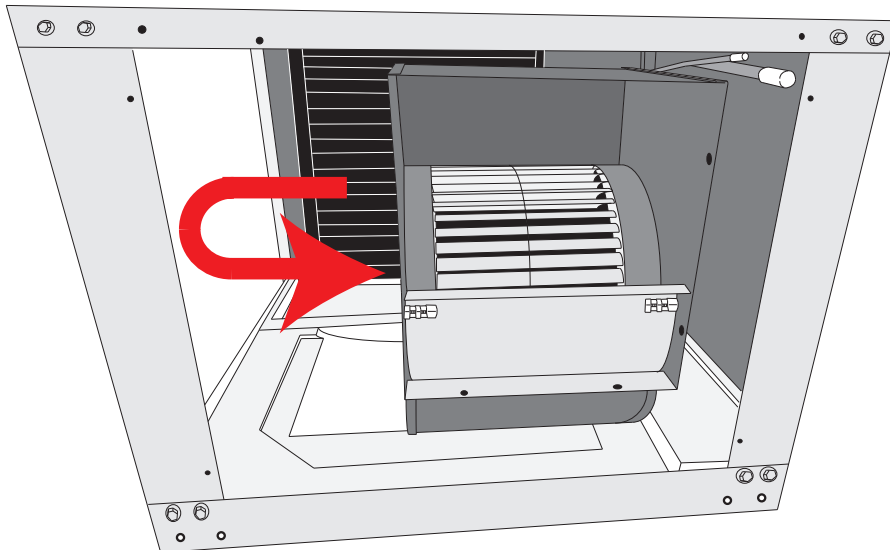

REAR BLOWER ORIENTATION INSTRUCTIONS, CONTINUED

7. Attach supply panel to rear of unit using removed six (6) removed screws.

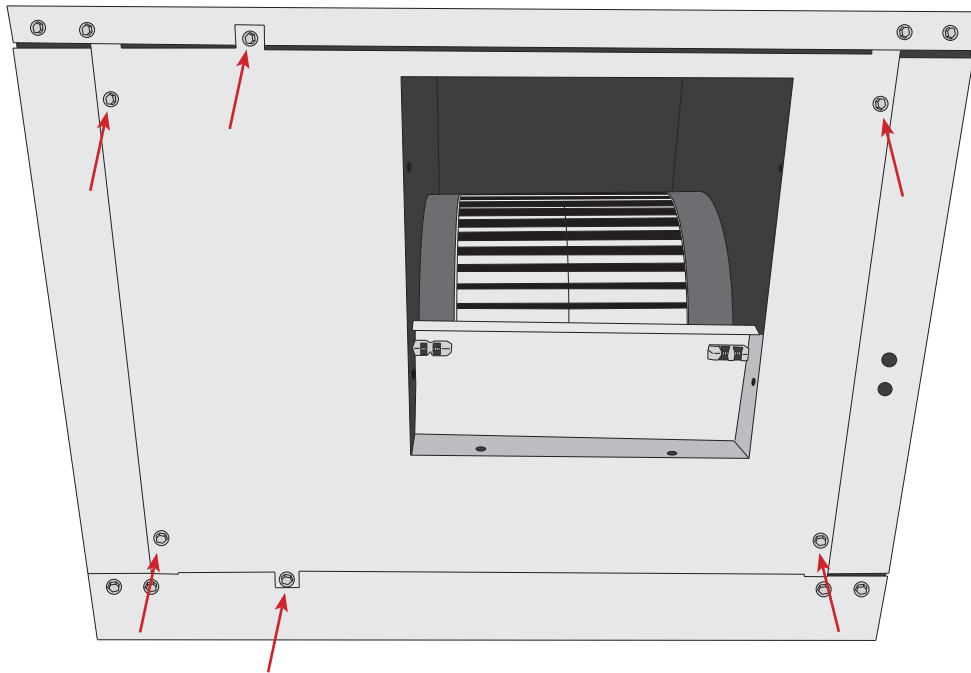

8. Secure blower to supply panel using the eight (8) screws removed earlier.

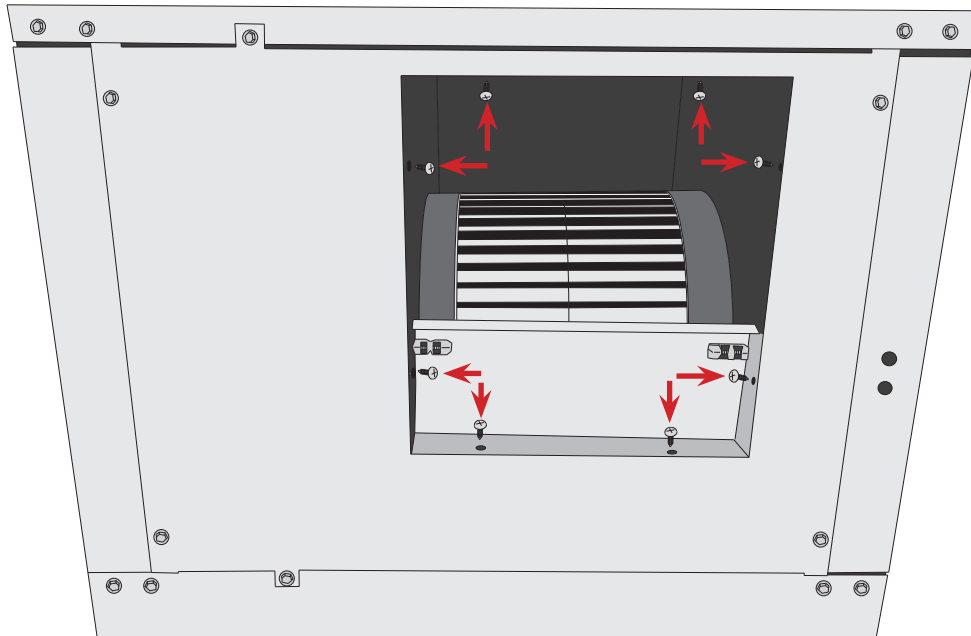

9. Reattach top panel with the six (6) screws removed earlier. Attach the panel which was formerly the rear panel on the right side of the unit where the supply panel was using the six (6) screws removed earlier. Blower reorientation is now complete.

TOP BLOWER ORIENTATION INSTRUCTIONS

If you wish to have the supply air duct and blower oriented toward the top of the unit, use the secondary foam fan bracket (packaged with the unit) pictured below. The purpose of this piece of foam is to enable you to orient the blower so that the supply air duct faces upward.

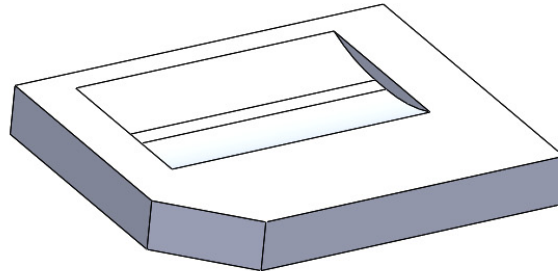

1. To reorient the blower, first remove the access panels on the rear and top of the unit.

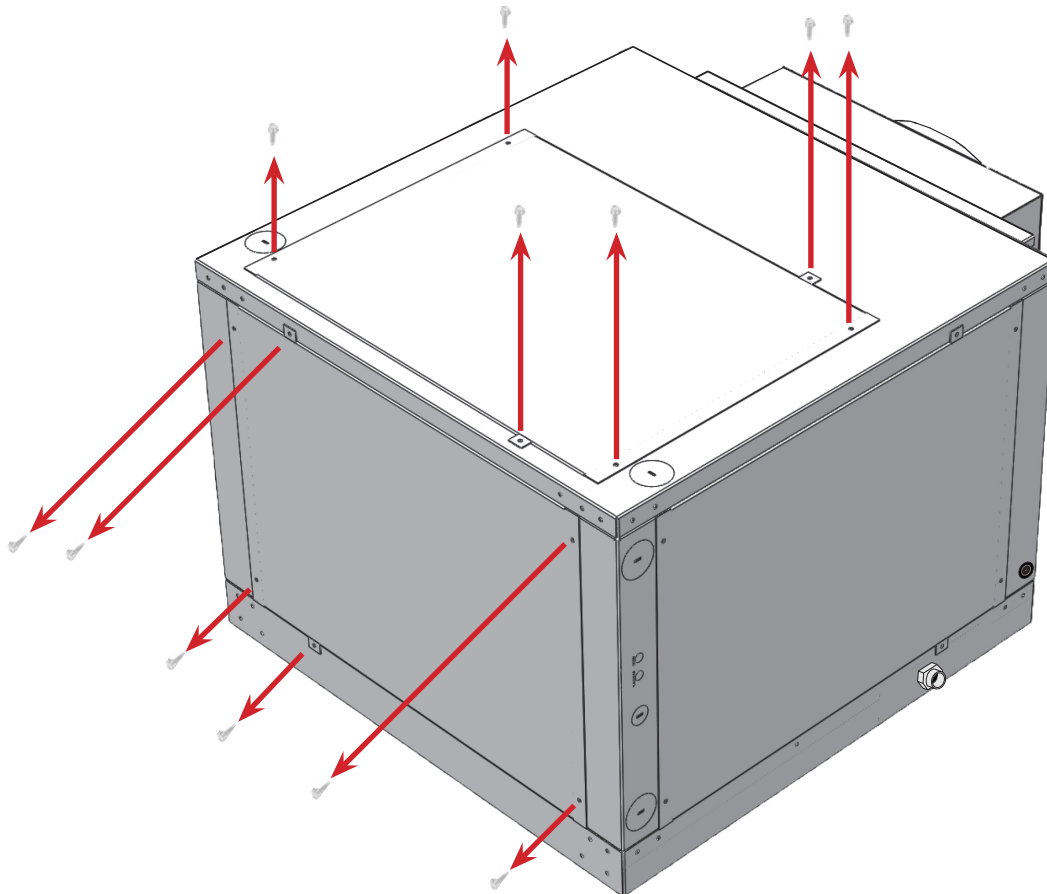

TOP BLOWER ORIENTATION INSTRUCTIONS, CONTINUED

2. Next, remove the eight (8) screws securing the blower to the supply panel.

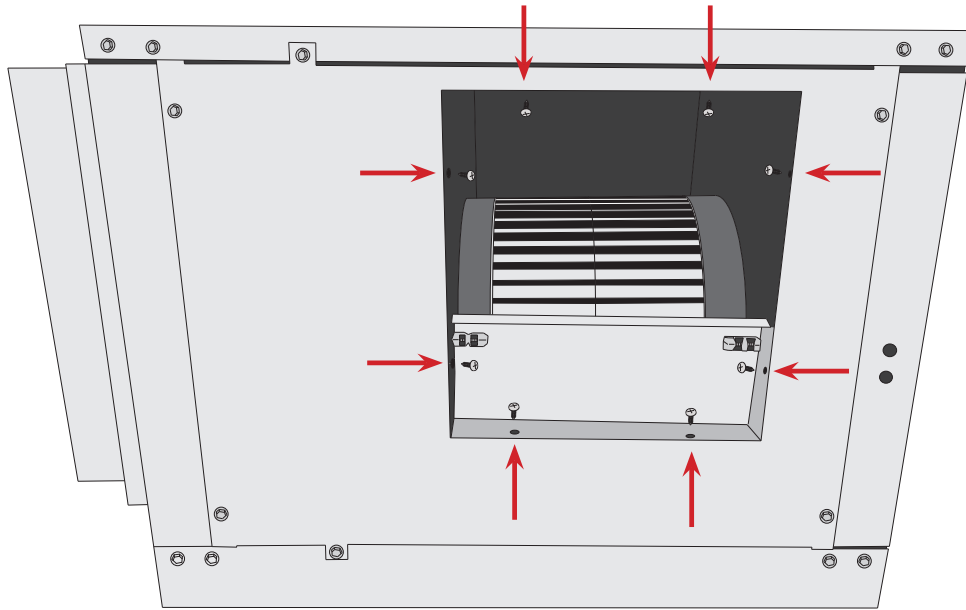

3. Remove the six (6) screws securing the supply panel to the unit housing.

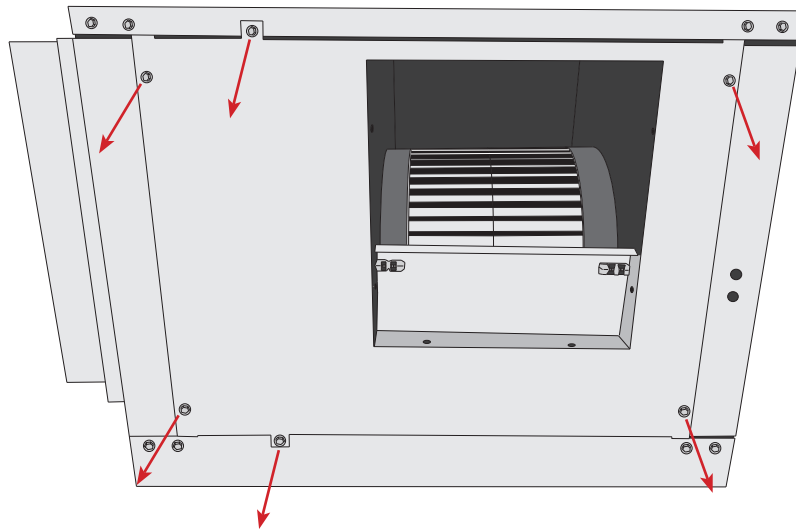

4. Remove the panel.

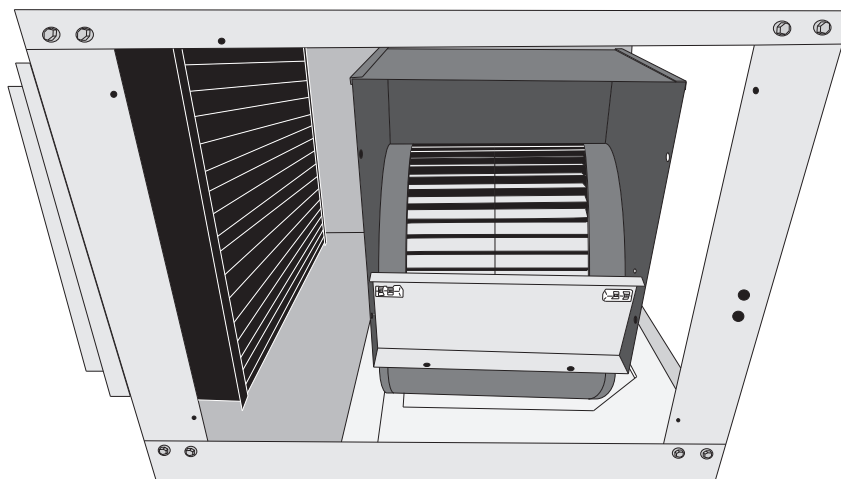

TOP BLOWER ORIENTATION INSTRUCTIONS, CONTINUED

5. Pull blower out through the rear access panel.

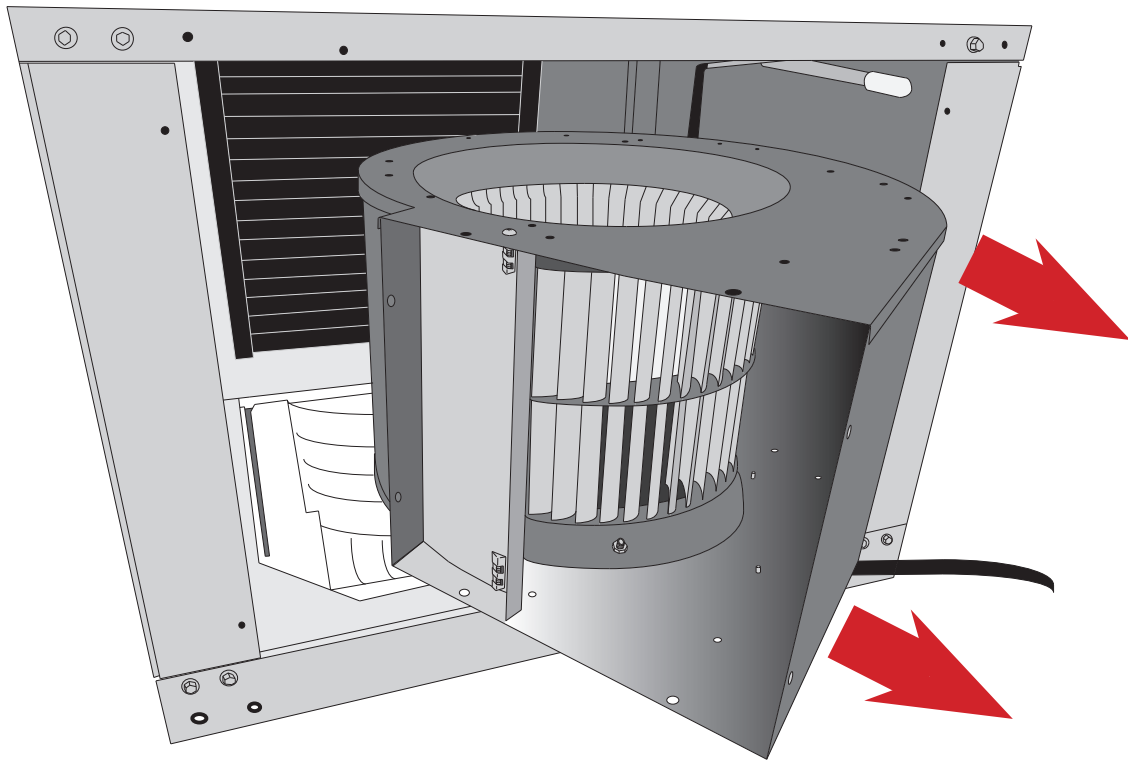

6. Set the piece of foam shown on page 16 into the foam fan bracket on the bottom of the unit housing.

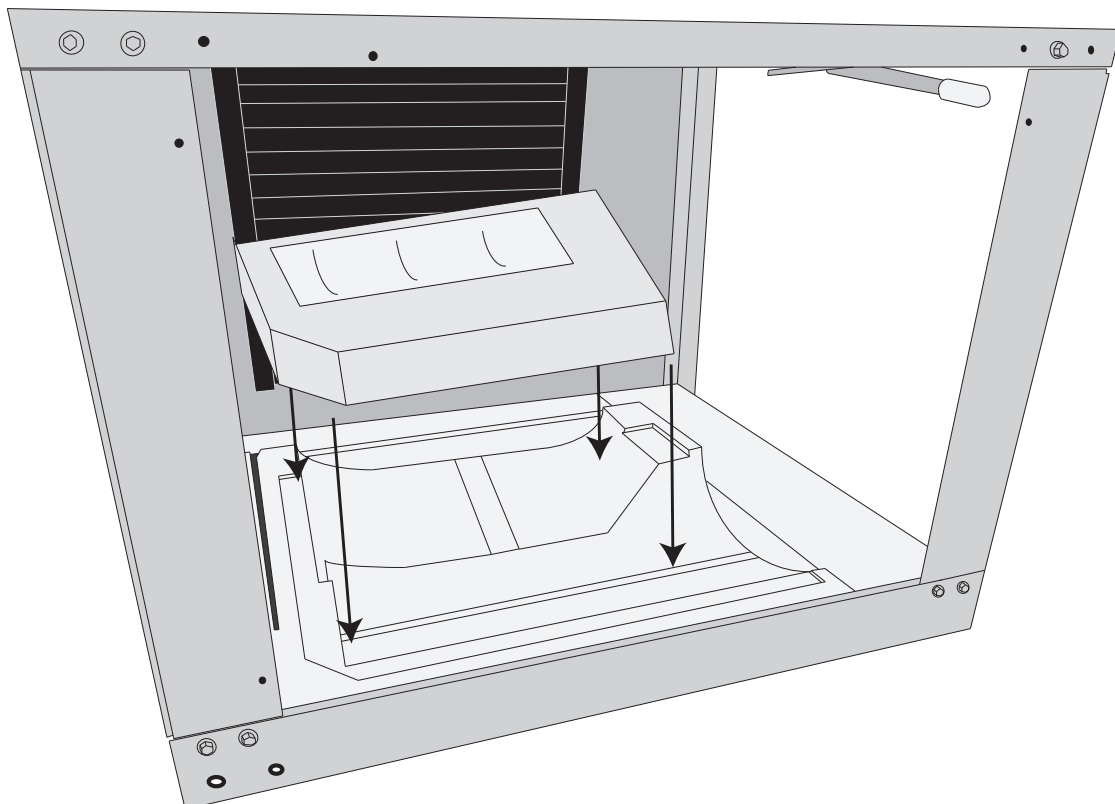

TOP BLOWER ORIENTATION INSTRUCTIONS, CONTINUED

7. Slide the blower in from the rear and set upright on the piece of foam.

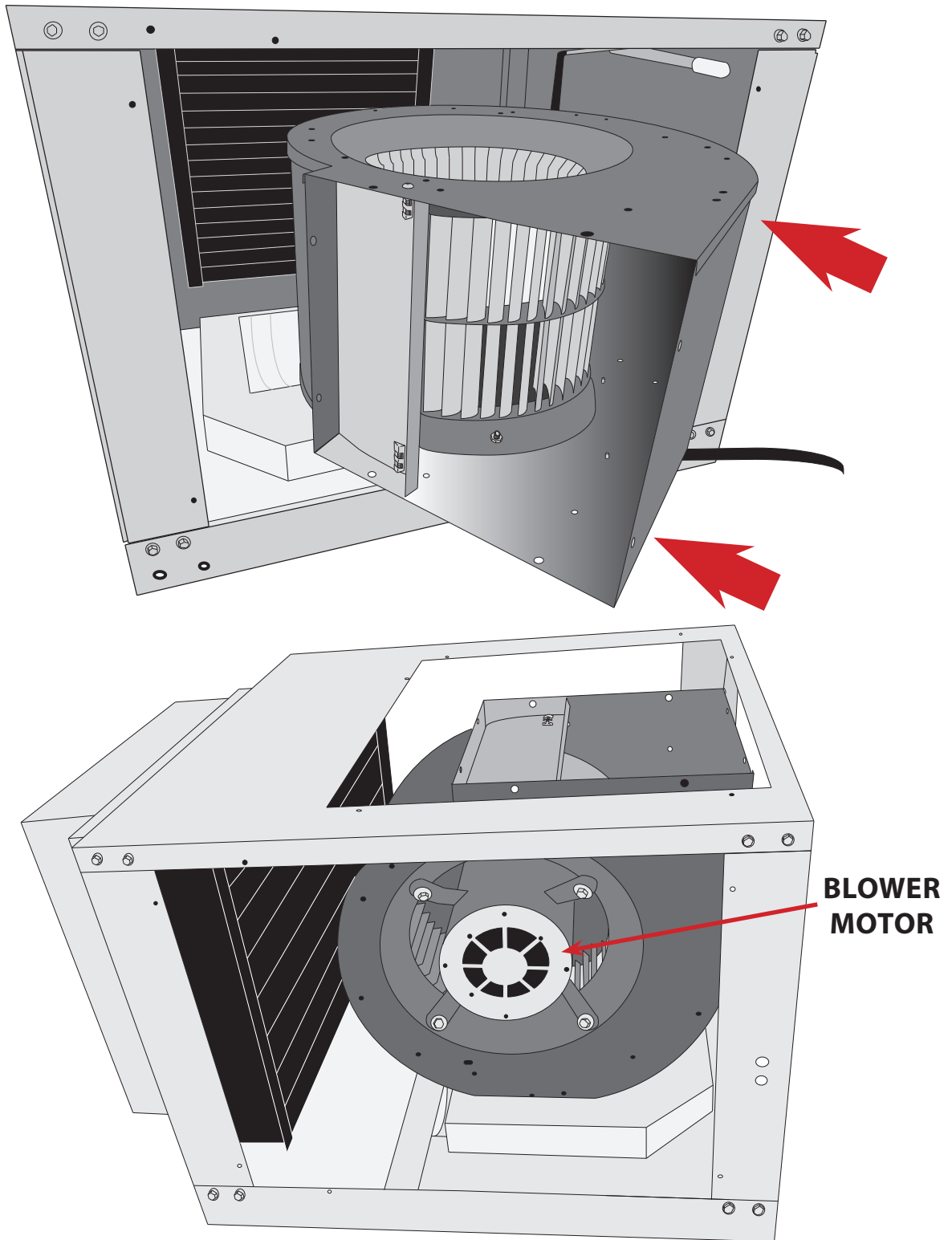

NOTE: Make sure that the blower motor is closest to the side access panel as shown above.

TOP BLOWER ORIENTATION INSTRUCTIONS, CONTINUED

8. Reattach the side panel using the eight (8) screws removed earlier.

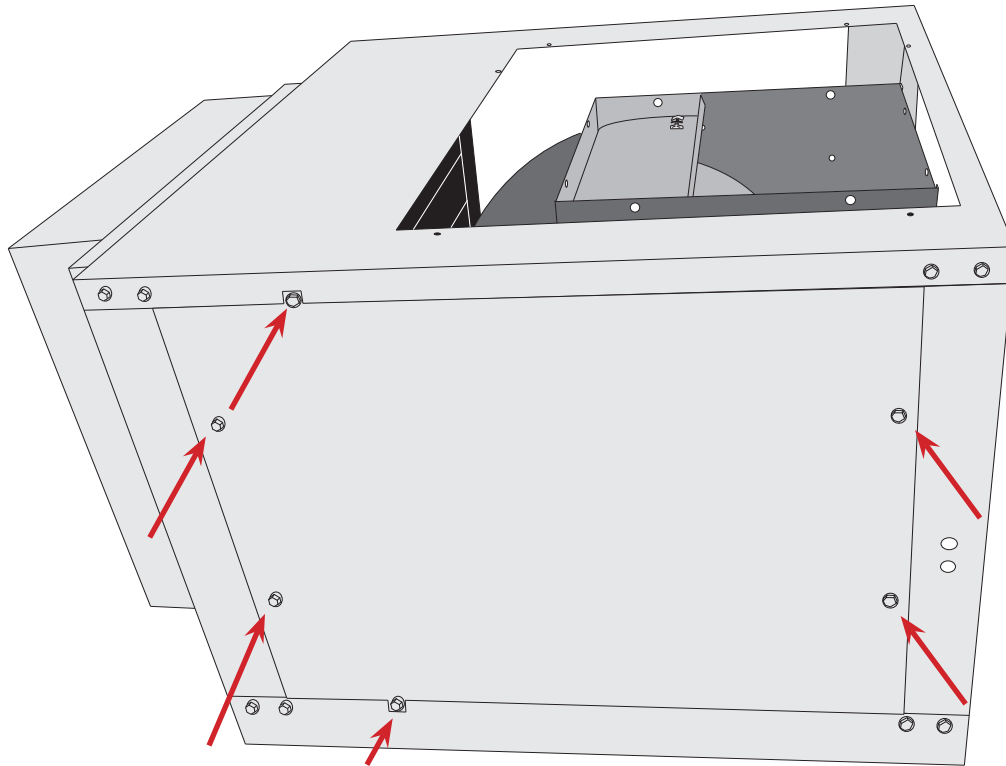

9. Attach the supply panel to the top of the unit using the six (6) screws removed earlier. Then attach the blower to the panel using the eight (8) screws removed earlier.

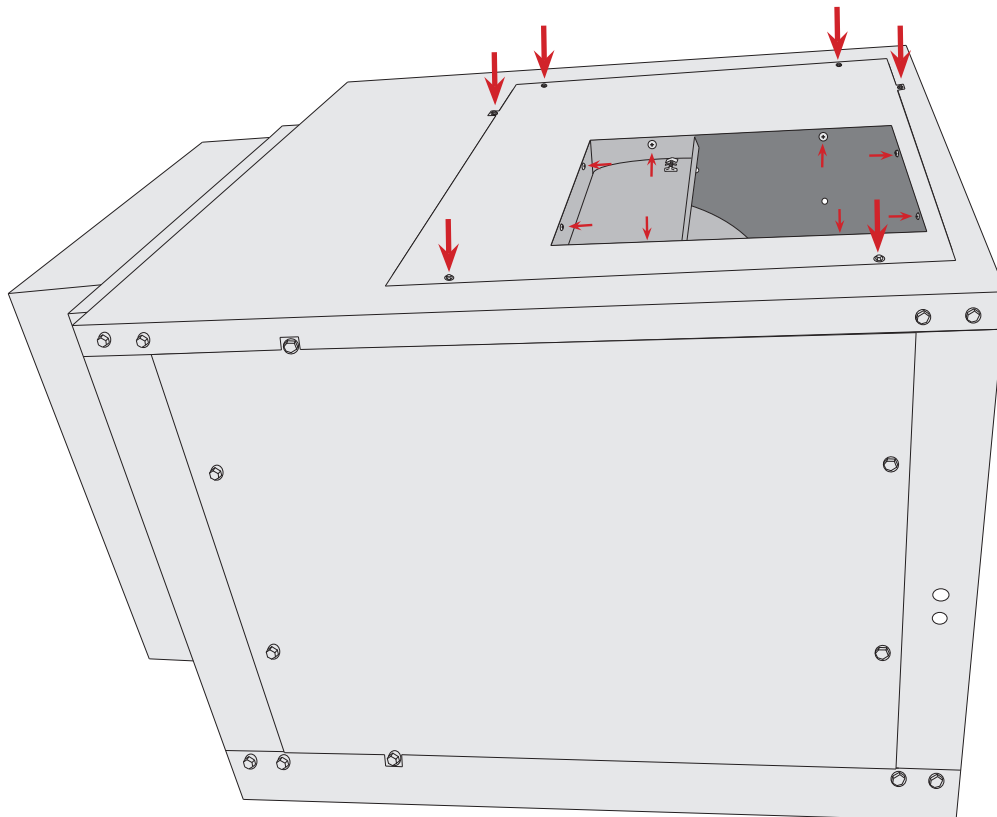

SQUARE-TO-ROUND PLENUM INSTALLATION*

1. Remove the backing from the double-sided tape on the flanges of the square-to-round plenum.

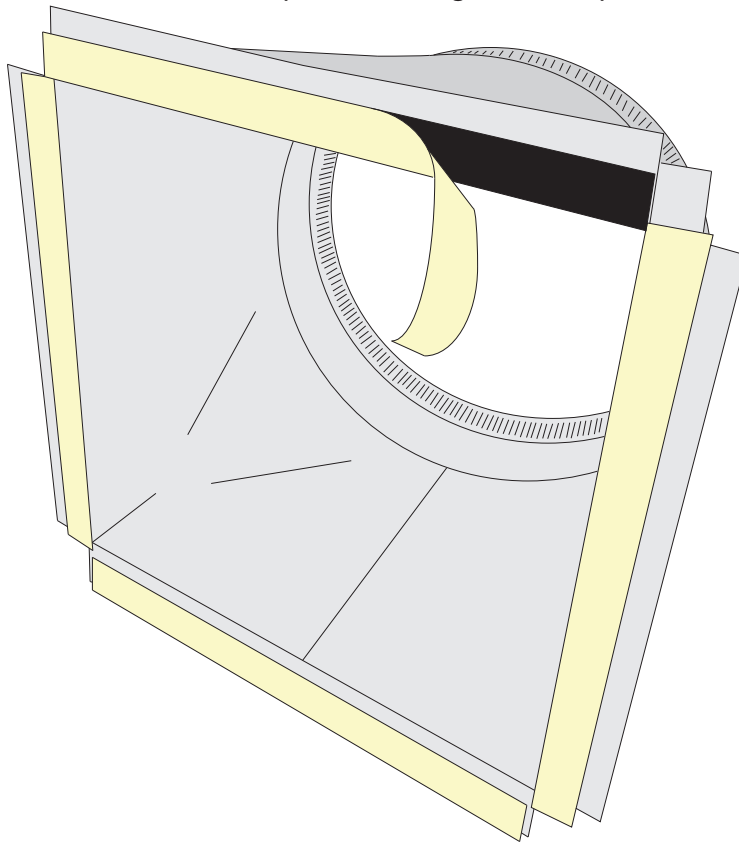

2. Stick the plenum onto the supply panel. **NOTE:** Make sure that the corners of the square-to-round plenum do not block the airflow from the blower.

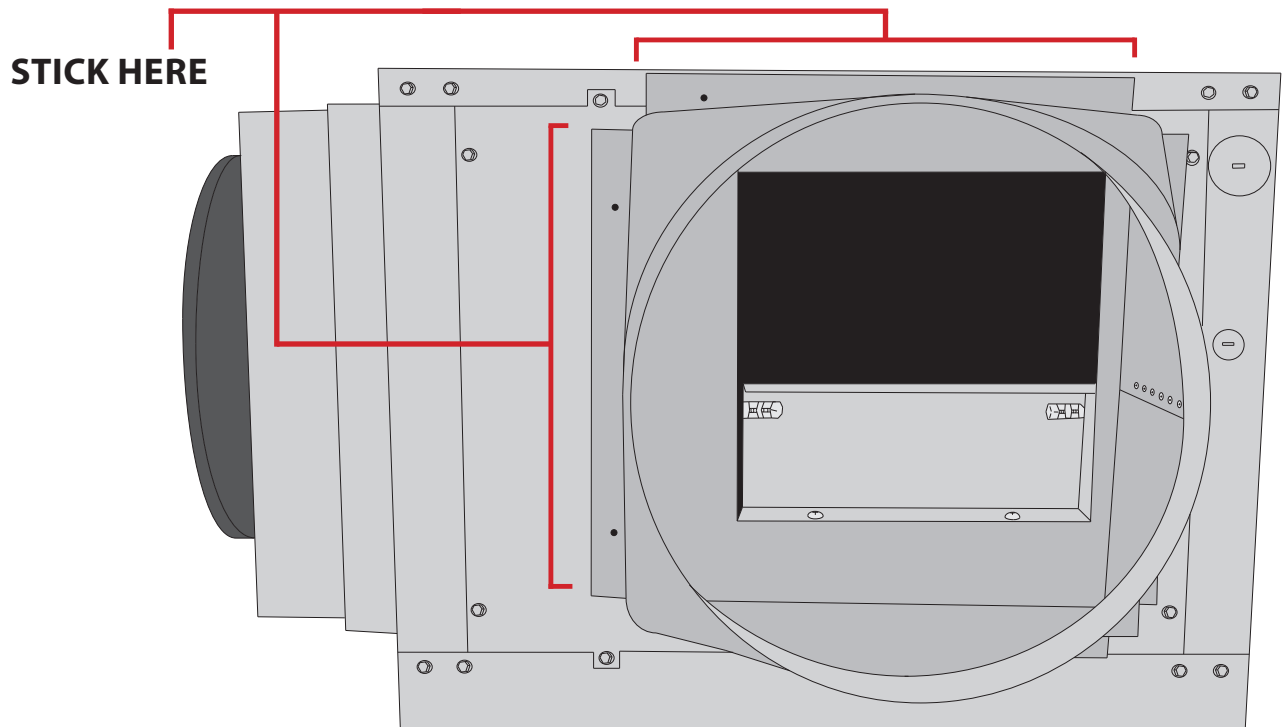

***Blower in rear orientation**

SQUARE-TO-ROUND PLENUM INSTALLATION, CONTINUED

3. Secure the square-to-round plenum to the housing with the provided #10-16 x 1/2" steel drilling screws.

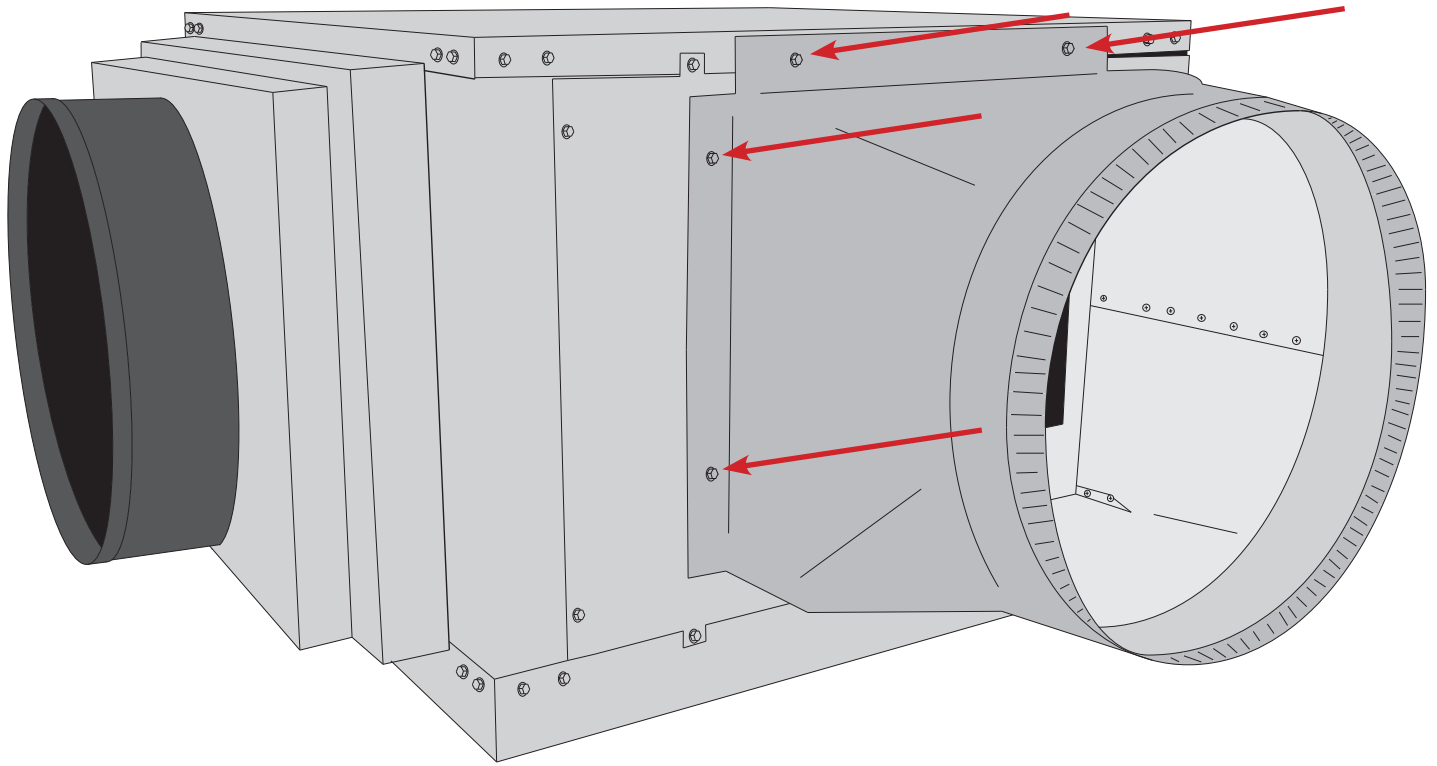

4. Seal all seams with foil tape.

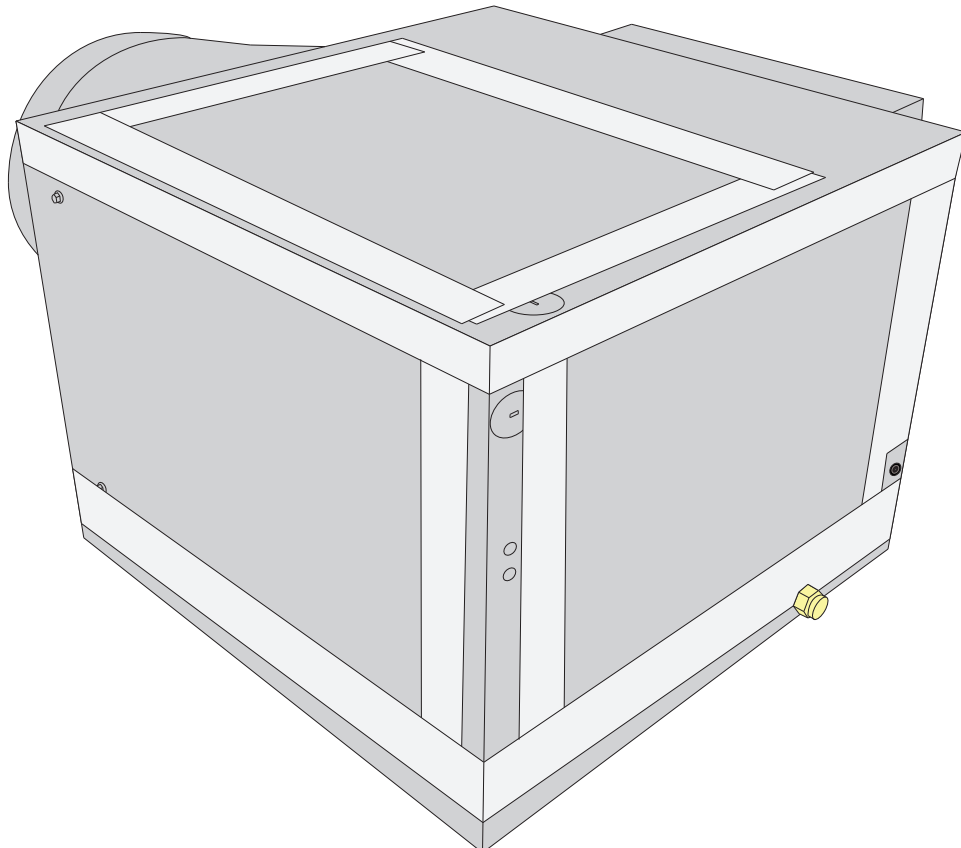

MOUNTING THE EVAPORATOR UNIT

Minimum Tools Needed:



Drill



Level

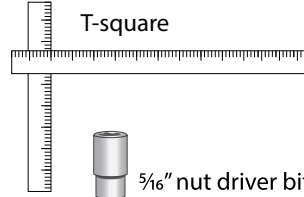

T-square

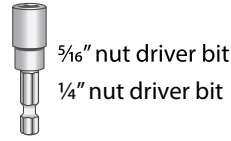

5/16" nut driver bit

1/4" nut driver bit

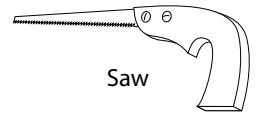

Saw

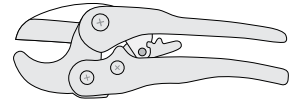

CPVC tube cutter

INSTALLING THE EVAPORATOR

1. Locate the desired installation location.
2. If utilizing an external or secondary drip tray, ensure the drip tray is installed on a level surface.
3. Use a stud finder to locate the ceiling joists. The ceiling joists will be the mounting surface for one end of the galvanized hanging straps. (**NOTE:** Plumber's tape/hanger strap not provided.) Cut four pieces of galvanized hanging straps long enough to extend from the ceiling joists to the screws located at the top corners of the evaporator unit.
4. If using a drill, set drill to 8 lbs. of torque to prevent stripping out the screw holes.
5. Using a 5/16" hex head nut driver, remove (1) screw from the top corner of the evaporator unit and route the screw through the appropriate hole on the hanger strap. Re-install the removed screw. Secure the free end of the hanger strap to the ceiling joist to prevent the evaporator unit from moving out of place. Repeat this step for the remaining three corners.

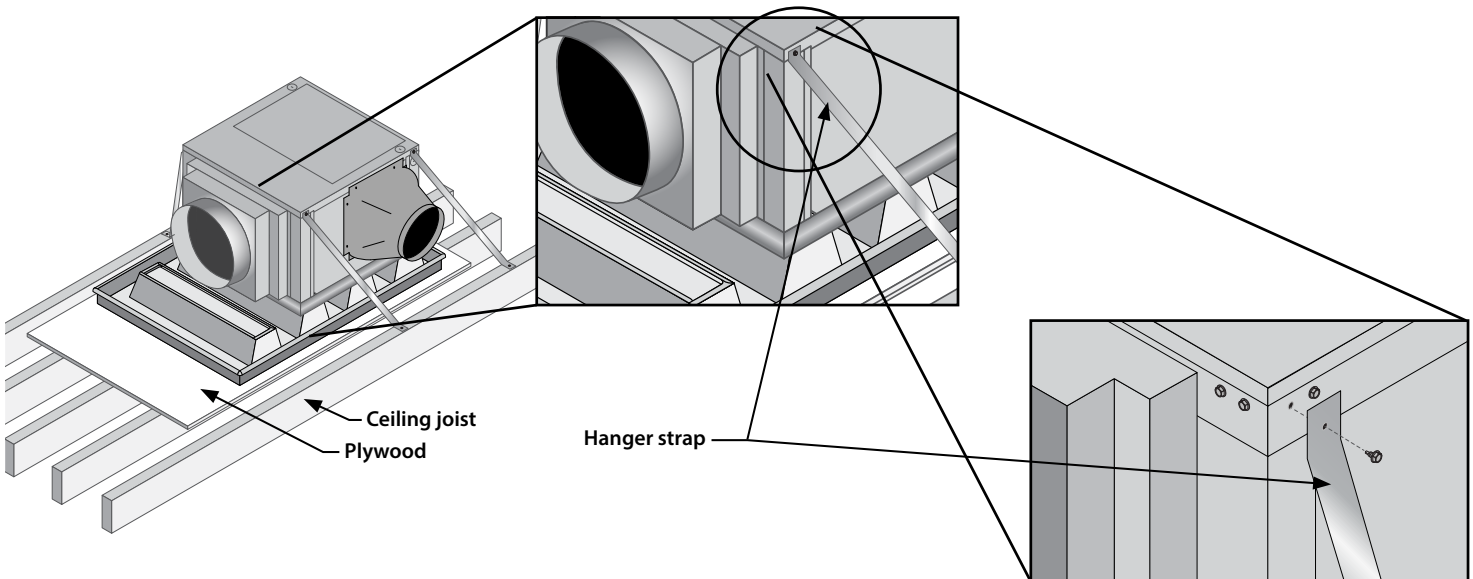

SYSTEM WIRING AND CONNECTIONS

ITEMS TO ROUTE BEFORE INSTALLING THE EVAPORATOR

1. Route the line set from the condensing unit to the desired evaporator installation location.
2. Route the display cable from the desired location to the evaporator installation location
3. Route the bottle probe cable from the desired thermostat bottle location to the evaporator installation location
4. Route the drain line from a proper discharge location to the evaporator installation location
5. Route the power cable wiring to the evaporator installation location.

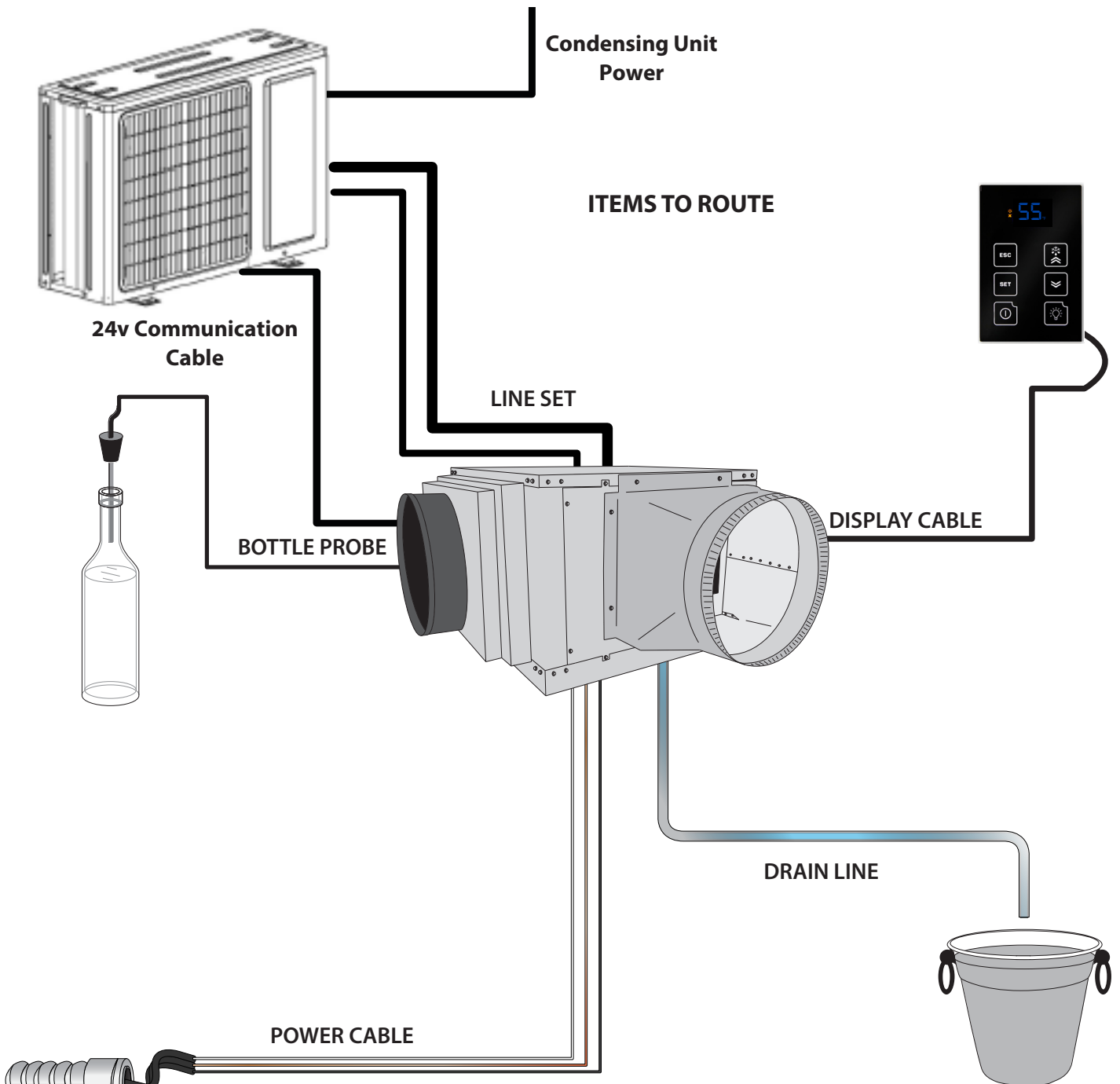

24V THERMOSTAT KIT WIRING INSTRUCTIONS

The 24V thermostat conversion kit requires a standard 18-5 thermostat wire to be run from the evaporator unit to the thermostat. The white wire will not be used, as there is no heating function. (Some thermostats need a common wire and some do not; the unit is equipped with a common wire if needed.) 18-5 thermostat wire (communication cable) must be run between the evaporator unit and the condensing unit.

24V Wiring Connections (Evaporator)

1. Route a standard 18-5 thermostat wire into the evaporator unit.
2. Locate the wire thermostat connection cable inside of the evaporator unit.
3. Connect the wires according to color (red to red, green to green, and blue to blue). Note: The evaporator unit will not contain a yellow wire. See next step for more information on Yellow wire.
4. Connect one wire from the 18-5 thermostat wire to the low-voltage yellow wire (1). Then connect the other 18-5 wire to the blue low-voltage wires (2). The other three wires will not be used.

Thermostat Wiring Connections

Follow the thermostat installation instructions. **NOTE:** The white wire will not be used, as there is no heating function.

NOTE: To ensure correct system operation, the 24V thermostat must be placed inside the wine cellar, preferably in a central location away from any airflow.

Thermostat

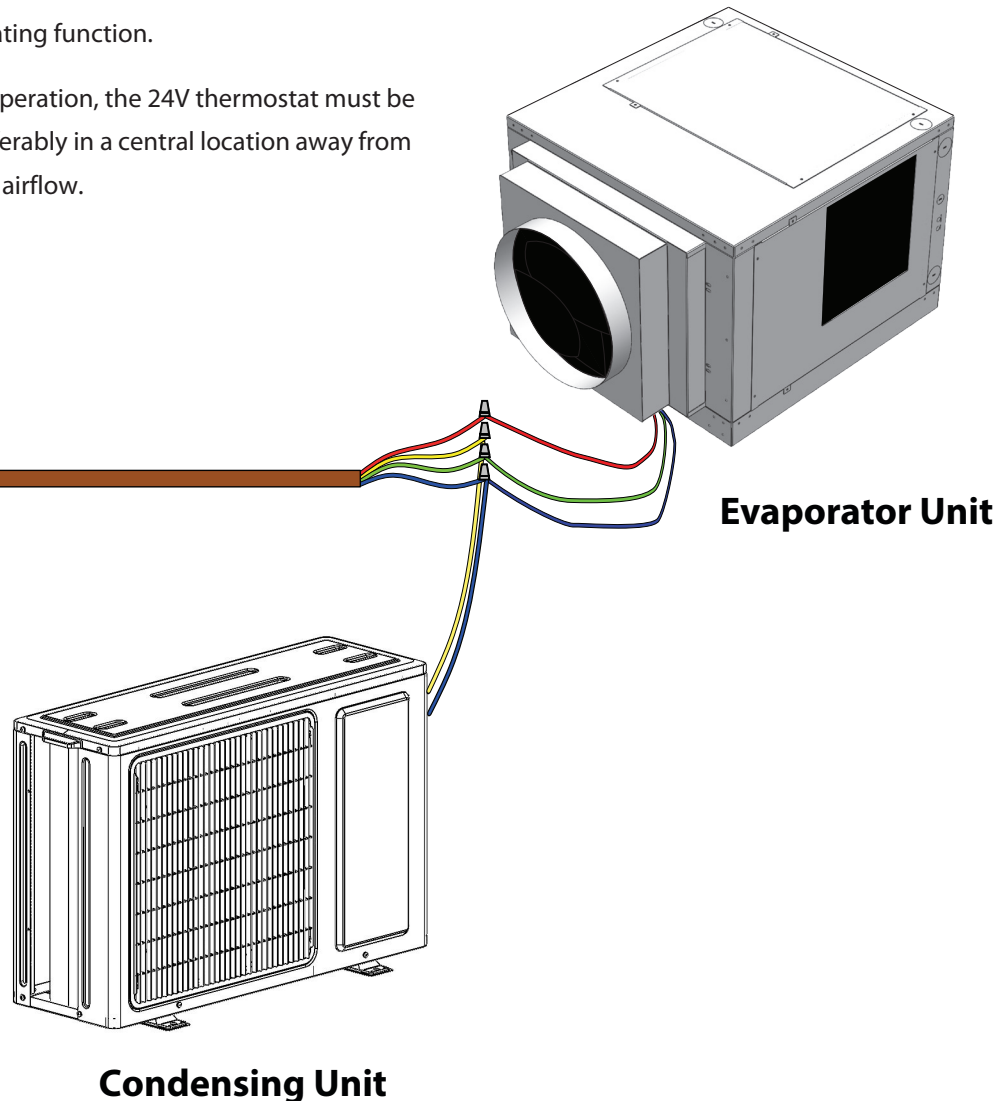

INSTALLING THE EVAPORATOR UNIT*

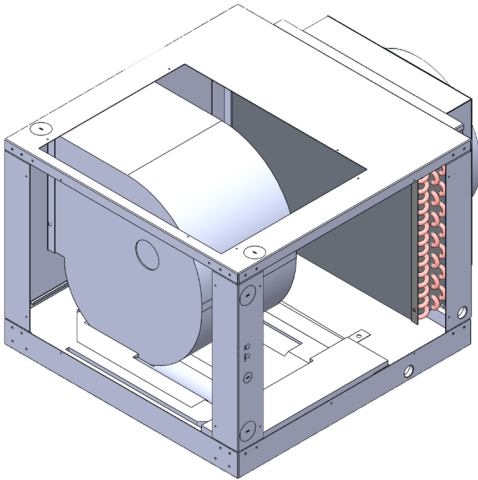

1. Unscrew and remove the top, rear and side access panels.
2. Remove the knockout(s) that you will be using to route the items on page 24 into the unit (line set, power wires, display cable, and bottle probe cable). See knockout options on page 7. Also remove insulation from behind the knockout holes.
3. Route the liquid and suction lines through the knockout in the housing.
4. Connect line set piping according to instructions
5. Install condensing unit before proceeding.
6. Route the power wires into the unit.
7. Connect the line voltage wire to the lever connector labeled "L."
8. Connect the neutral wire to the lever connector labeled "N."
9. Connect the ground wire to the green bare-end wire labeled "GROUND."
10. Install one of the 13/32" grommets in the hole labeled "DISPLAY."
11. Route the display cable through the knockout and into the unit as shown in Figure 1.

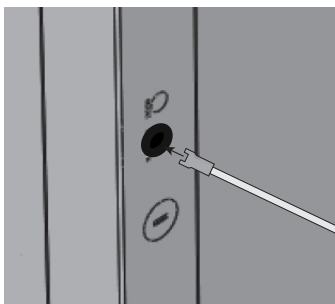
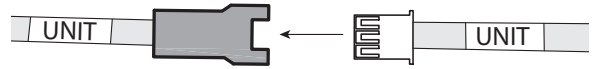

FIG. 1

12. Connect the end of the display cable labeled "UNIT" to the wire labeled "UNIT" coming from the controller box.



13. Install the supplied piece of cork tape around the display cable as shown in Figure 2.



FIG. 2

14. Route the display cable to the desired location.
15. Remove the nut from the circular connector wire which is located in the corner behind the bottle probe knockout.
16. Insert the circular connector into the hole labeled "BOTTLE PROBE" and secure using the nut removed in previous step.
17. Connect 50-foot bottle probe to circular connector on exterior of unit.

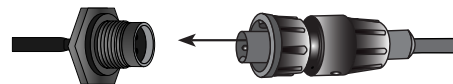

18. Insulate the suction line using Armaflex or similar insulation.
19. Set torque setting on drill to 8lbs and reinstall the top, rear, and side panel using the screws removed.
20. Using Nashua foil tape or equivalent, cover all seams.

*Ensure that the left side of the evaporator unit (where the electrical box is located) remains accessible after installation.

CONNECTING THE LINESET

Connect the refrigerant piping according to these instructions

1. Cut the pipes

When cutting the pipes make sure to take extra care and cut and flare them properly. This will ensure a proper connection and minimize the need for maintenance

- Measure the distance between the indoor and outdoor units
- Using a pipe cutter, cut the pipe a little bit longer than the measured distance
- Make sure that the pipe is cut at a perfect 90° angle. Refer to the example

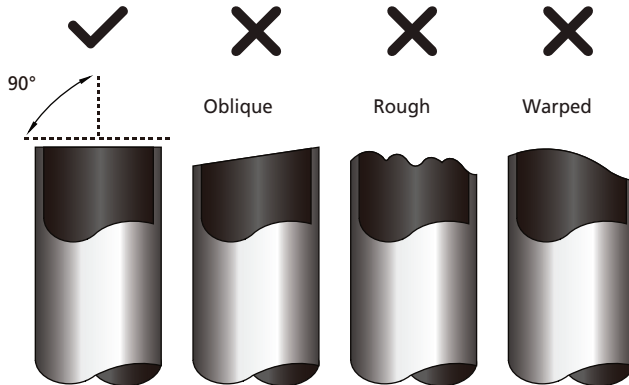

2. Remove Burrs

Burrs can affect the air tight seal of refrigerant piping connection. They must be completely removed

- Hold the pipe at a downward angle to prevent burrs from falling into the pipe
- Using a reamer or deburring tool, remove all burrs from the cut section of the pipe

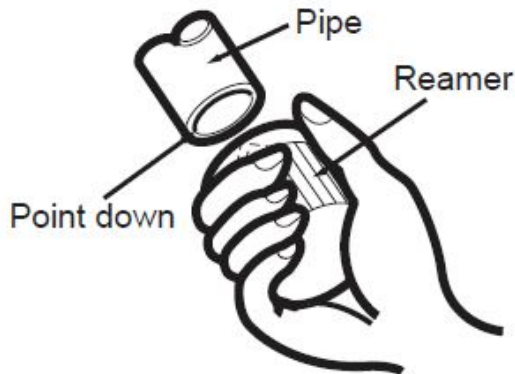

3. Flare pipe ends

Proper flaring is essential to achieve an airtight seal

- After Removing burrs from cut pipe, seal the ends with PVC tape to prevent foreign materials from entering the pipe
- Sheath the pipe with insulating material
- Place flare nuts on both ends of pipe. (Flare nuts provided with lineset.) Make sure they are facing the right direction. After flaring the pipe the nuts will not be removable. Remove PVC tape ends of pipe when ready to perform flare work
- Clamp flare form on end of pipe must extend beyond the edge of the flare form in accordance with the dimensions in the table below

CONNECTING THE LINESET, CONTINUED

PIPING EXTENSION BEYOND FLARE FORM

Outer Diameter of Pipe (in)	A (in.)	
	Min.	Max.
Ø 1/4"	0.0275"	0.05"
Ø 3/8"	0.04"	0.063"
Ø 1/2"	0.04"	0.07"
Ø 5/8"	0.078"	0.086"
Ø 3/4"	0.078"	0.094"

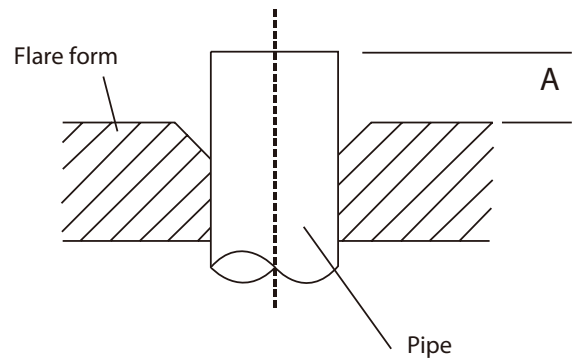

- Place flaring tool onto form
- Turn the handle of the flaring tool clockwise until the pipe is fully flared
- Remove the flaring tool and flare form, then inspect the ends for any cracks and make sure the flaring is even.

4. Connect pipes

When connecting refrigerant pipes, be careful not to use any excessive torque or to deform the piping in any way. You should first connect the low-pressure pipe, then the high pressure pipe. It is recommended to use a CFC and HCFC compatible thread sealant on all threaded pipe connections.

- Align the center of the two pipes that will be connected. To prevent gas leakage, apply refrigeration oil only to the inner surface of the flare. Use torque wrenches when tightening the flare nuts to prevent damage to the flare nuts and gas leakage
- Tighten the flare nut as tight as possible by hand
- Using a spanner, grip the nut on the unit tubing

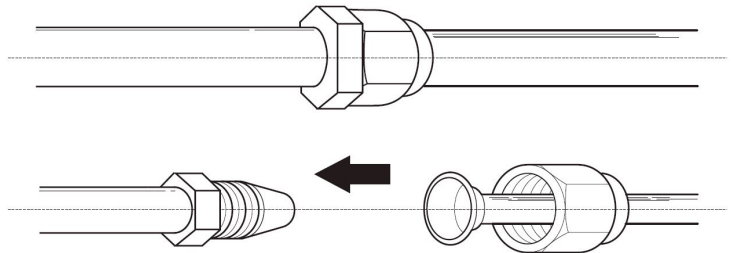

- While firmly gripping the nut on the unit tubing, use a torque wrench to tighten the flare nut according to the torque values in the Torque Requirements table below. Loosen the flaring nut slightly, then tighten again. Prior to applying recommended torque to brass flare nut, it is highly recommended a small amount of refrigeration oil be applied to the flare threads, flare sealing surface, and copper tubing flared surface to prevent galling of sealing surfaces and aid in providing a refrigerant tight seal (Use refrigeration oil for R134a). Be careful not to overtighten the connection as this may damage the flare or fitting.

TORQUE REQUIREMENTS

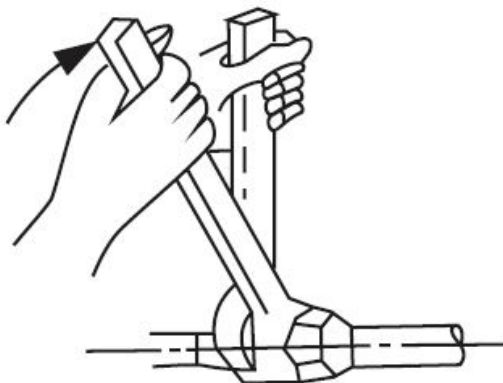

Outer Diameter of Pipe (in.)	Tightening Torque (lb•ft)
Ø 1/4"	11lb•ft
Ø 3/8"	18.4lb•ft
Ø 1/2"	25.8lb•ft
Ø 5/8"	33.19lb•ft
Ø 3/4"	47.94lb•ft

DRAINAGE

Condensation Drain Line

The condensation drain line tube is used to remove excess condensation from the unit to a proper discharge location. It is important that the drain line tube be properly connected. The discharge location cannot be a secondary drain pan. Both condensate drain lines should discharge to different locations, and the secondary drain pan should discharge to an easily accessible and/or conspicuous location so the customer can monitor it.

Drain Line

The Quantum evaporator unit accepts 3/4" CPVC tubing. It is imperative that you use primer and glue to ensure there is a watertight seal between the tubing and all fittings. All joints and connections should be made in accordance with the applicable provisions of Chapter VII of the International Plumbing Code (relative to the material type). Condensate drain line size shall not be less than 3/4-inch (9mm) internal diameter and shall not decrease in size from the drain pan connection to the place of condensate disposal.

Such piping shall maintain at least a one-percent slope in the direction of discharge (not less than one-eighth of a vertical inch for every twelve horizontal inches). Condensate shall not discharge into a street, alley, or other areas so as to cause a nuisance.

P-Trap Required

A P-trap must be connected to the unit to ensure proper drainage of condensation. On the next page is a detailed diagram of how the P-trap should be constructed. The threaded fitting on the end of the tube will allow for easy cleaning of the drain port, and must be installed using plumber's tape or equivalent sealant.

WARNING

Failure to install a P-trap will prevent the unit from draining correctly and may cause numerous other problems, including but not limited to:

- ↳ The cooling system shutting off due to high condensation levels in the internal drain pan
- ↳ The internal drain pan overflowing
- ↳ Water damage to wine cellar and/or surrounding areas
- ↳ Ruination of the customer's wine collection

Failure to install a P-trap as specified in this manual will void the warranty.

DRAINAGE, CONTINUED

Internal Float Switch

The evaporator unit comes equipped with a float switch to monitor the level of condensation in the internal drain pan. If the drain line is obstructed for some reason, and the water level in the drain pan gets too high, the controller will send an alarm to the display. The alarm message displayed will be "EA". The system will continue to run if the DOA has not been changed to 5. The factory setting allows the unit to run even if the EA alarm is tripped. The alarm will be corrected when the water level inside the drip pan decreases and the float switch becomes disengaged.

All joints and connections shall be made in accordance with the applicable provisions of Chapter 7 of the International Plumbing Code relative to the material type. Condensate waste and drain line size shall be not less than 3/4 inch (19 mm) internal diameter and shall not decrease in size from the drain pan connection to the place of condensate disposal.

P-TRAP CONFIGURATION

Below is a detailed diagram of how the P-trap should be constructed.

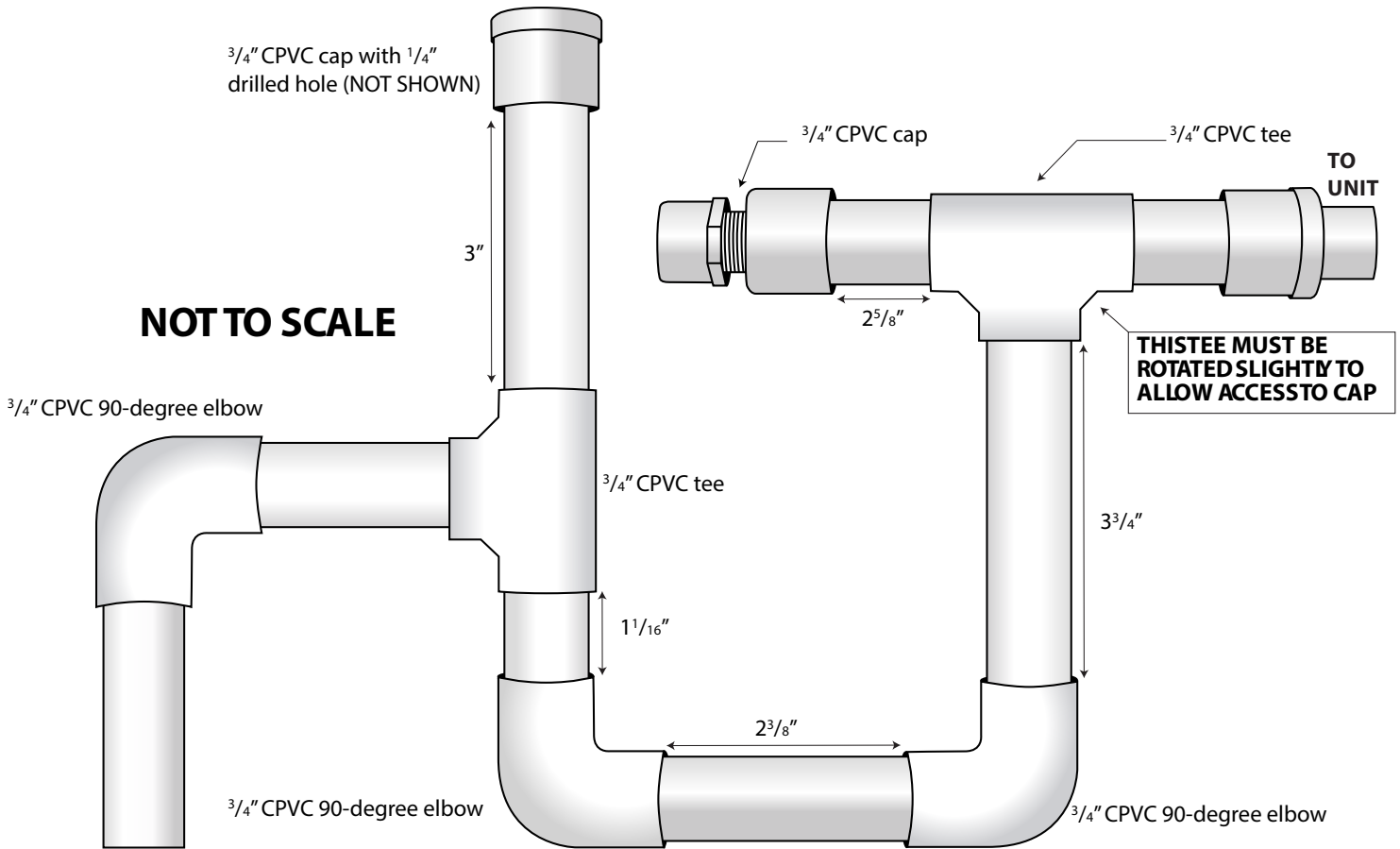

NOTE: Use a soft tube-cleaning brush to clean out the drain line. Failure to use a soft brush could damage the drip tray of the unit and void the warranty.

Connecting the Drain Line

Apply CPVC primer and glue to the female fitting coming from the unit and the CPVC tube which will be connected to it.

Insert the a piece of CPVC tubing into the female fitting.

Route additional CPVC tubing to an appropriate discharge location. (Tubing is not provided.)

Every six weeks, remove the 3/4" CPVC cap and run a drain line brush through the T-junction until all sludge and slime is removed.



WRONG: Drain line is under water. To prevent mold from growing and to ensure proper drainage, allow the drain line to hang above the waterline.

LIQUID-MEASURING THERMOSTAT SYSTEM (BOTTLE PROBE)

WhisperKOOL cooling units come with a liquid-temperature-measuring thermostat. The self-calibrating probe contains a sensor chip, which communicates back and forth with the thermostat. This results in a consistent temperature setting and accuracy. Wine should be kept at a very precise, controlled temperature and humidity.

Setting up the Bottle Probe:

1. Locate an empty wine bottle.
2. Fill it 75% full with room-temperature tap water.
3. Place bottle probe securely into bottle as seen in Figure 1.
4. Place bottle off to the side of the unit in your wine cellar, with the probe level.
5. To ensure a consistent temperature, place bottle probe approximately three (3) feet away from the air output and not in the flow of the air.

It is recommended that the bottle be placed in a central location of your wine cellar. Avoid pulling too much on the probe cord. It may become disconnected resulting in limited functionality of the unit.

Note: The thermostat can be set between 50–70°F.

Remember: The unit operates based on the temperature of the water. Do not be misled by thermostats reading air temperature. The air temperature in the cellar will be cooler than the liquid temperature of the wine while it is reaching the optimum balanced temperature.

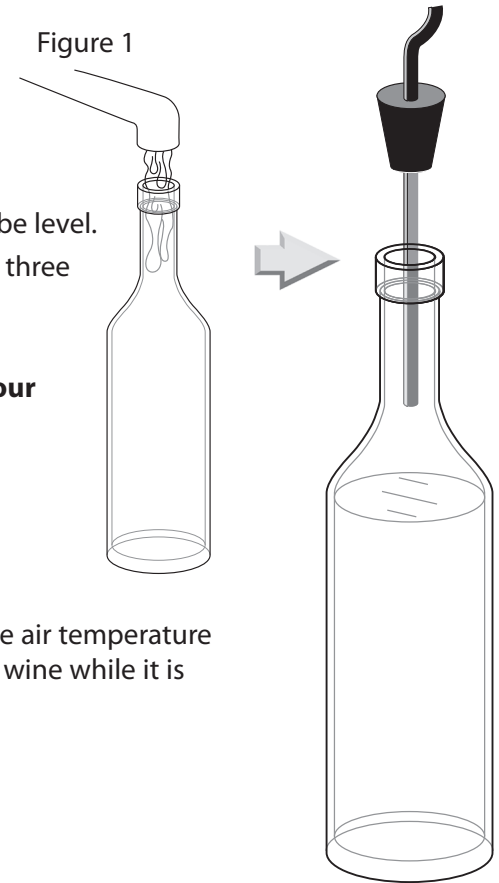

REMOTE DISPLAY: INSTALLATION AND CONFIGURATION

Tools needed: 5/16" drill bit, 3/16" drill bit, drywall saw, level, pencil **What's included:** Display panel, wall mount bracket, flush mount bracket, flush mount template



Display panel

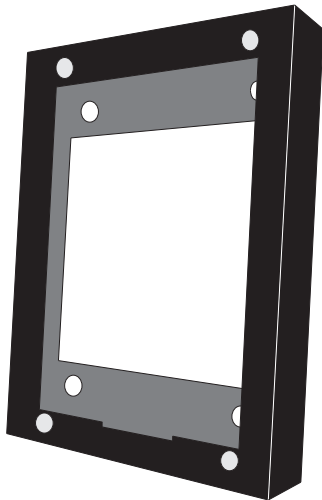

Wall mount bracket



Flush mount bracket

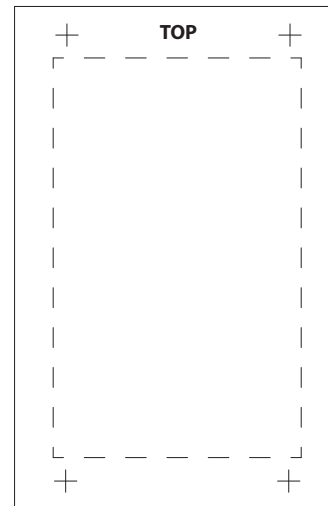

Flush mount template

WALL MOUNT BRACKET INSTALLATION

1. Place the bracket on the wall. Use a level to ensure that the bracket is level. Using a pencil, mark the four screw holes in the rear of the bracket.

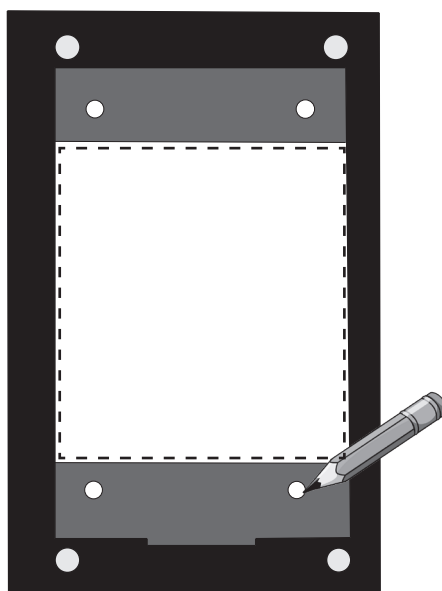

NOTE: Cut hole in the location shown for routing the display cable.

WALL MOUNT BRACKET INSTALLATION, CONTINUED

2. Using a drill with a 3/16" bit, drill four holes in the drywall for the screws. Insert the four (4) provided drywall anchors into the drywall, then tap them in with a hammer until they are flush with the wall.

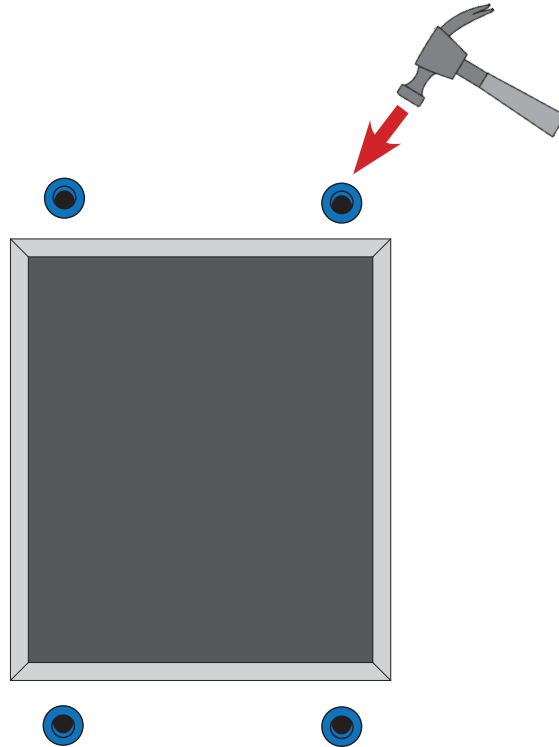

3. Place bracket against wall, aligning screw holes with drywall anchors. Insert the four supplied Phillips-head screws into the drywall anchors. Tighten the screws to secure the bracket to the wall.

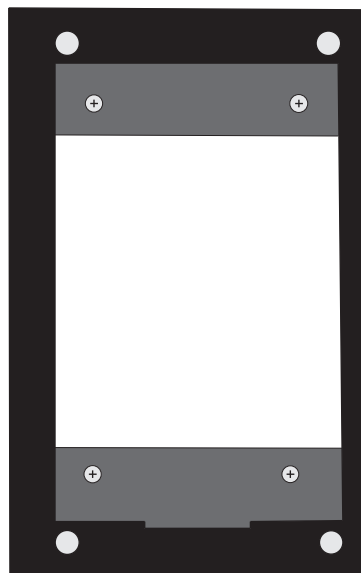

WALL MOUNT BRACKET INSTALLATION, CONTINUED

NOTE: Before you continue to Step 4, locate the area where the display will be mounted. You may route the display wire into the housing one of three ways: either through the wall or through one of the holes on the top or bottom edges of the wall mount bracket. If you'd like to route the display cable through one of these holes, place a rubber grommet into the hole and then route the display cable through the grommet and into the wall mount bracket.

4. Connect the end of the display cable labeled **"DISPLAY"** to the JST connector on the back of the display.

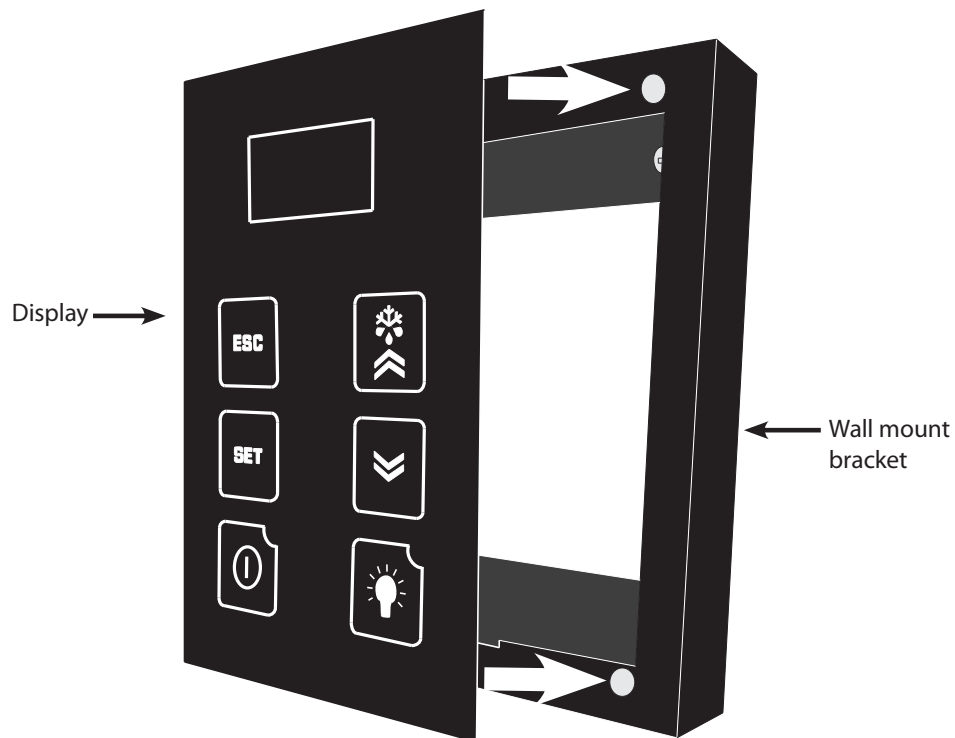
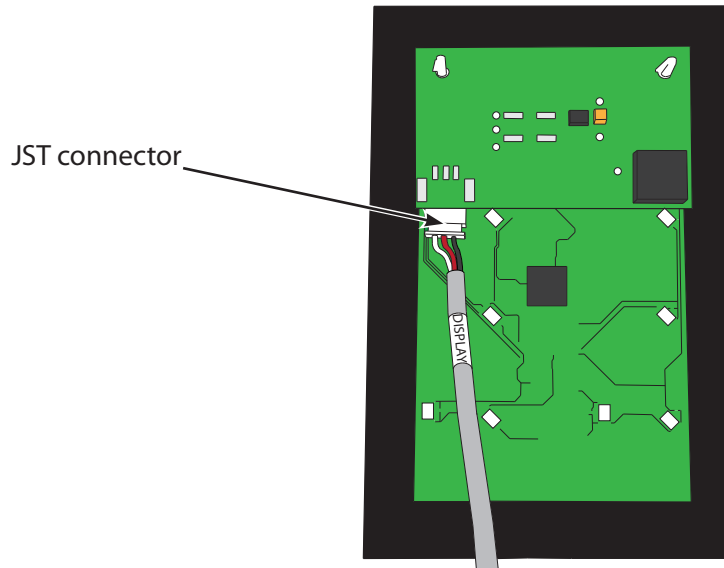

5. Place the display on the wall mount bracket as shown, attaching the back of the display panel to the magnets on the mounting bracket. Make sure that the alignment tab on the back of the display panel sits in the notch on the bottom of the bracket.

FLUSH MOUNT BRACKET INSTALLATION

1. Square the flush mount template on the wall using a level. Then draw a 3" line along the bottom edge of the template.

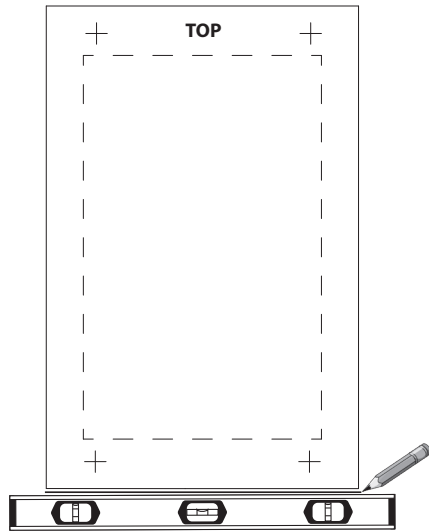

2. Peel the backing off the template and stick it to the wall, aligning the bottom edge with the line drawn in Step 1.

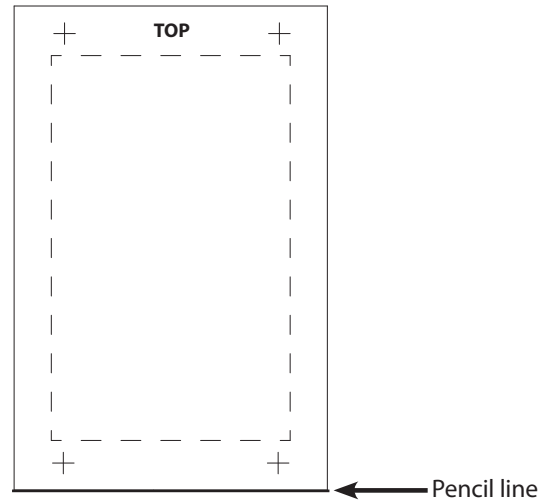

3. Use a 5/16" drill bit to drill a hole in the center of each cross (+).

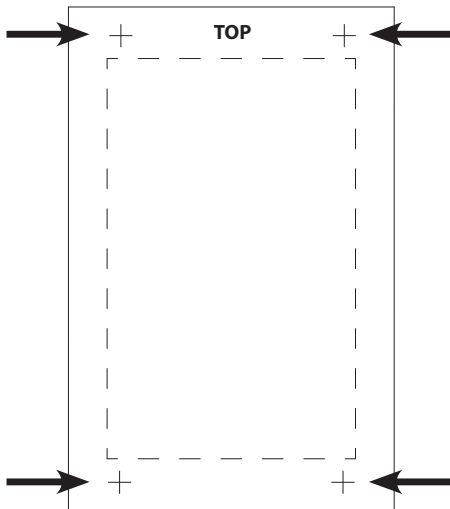

4. Cut along the perforated lines. When finished, remove template from wall.

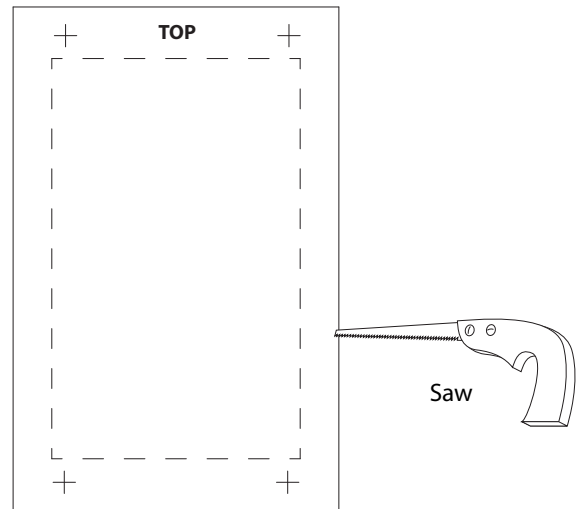

FLUSH MOUNT BRACKET INSTALLATION, CONTINUED

5. Remove the backing from the double-sided tape on the flush mount bracket.



6. Align magnets with previously drilled holes. Make sure the cut-out portion of the bracket (circled below) is on the bottom. Press the bracket firmly against the wall.

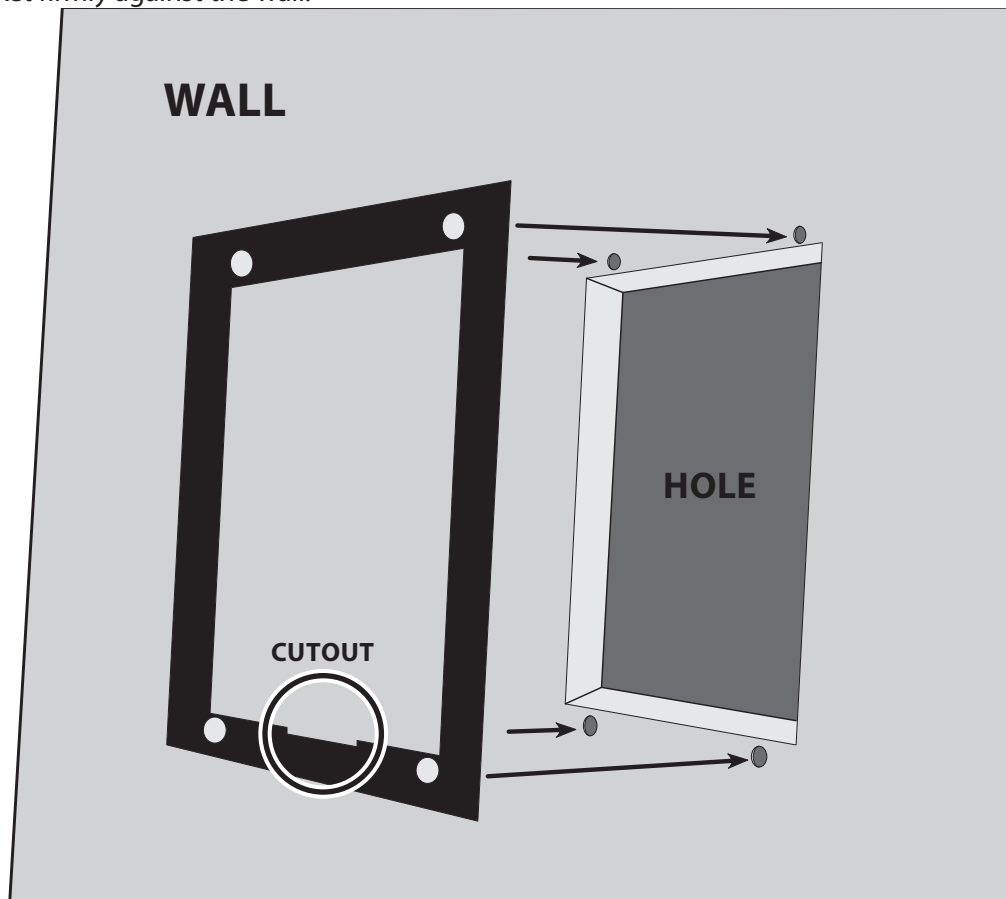

FLUSH MOUNT BRACKET INSTALLATION, CONTINUED

7. Connect the end of the display cable to the JST connector on the display panel.

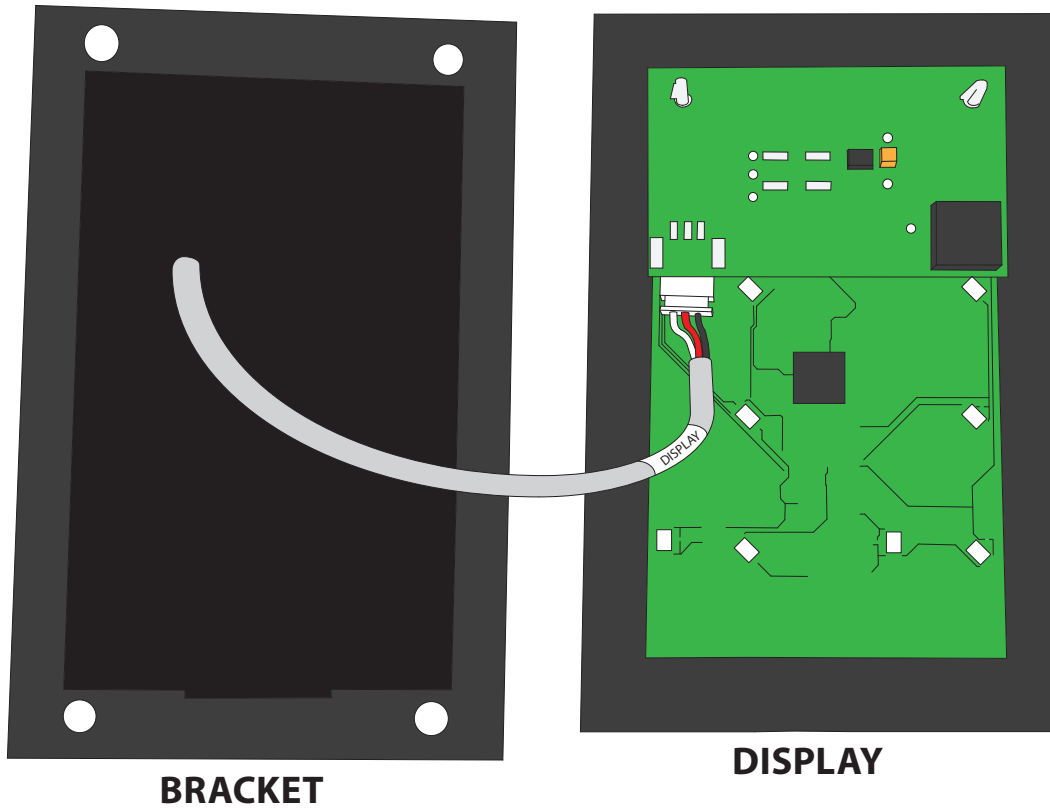

8. Place the display on the flush mount bracket as shown, attaching the back of the display panel to the magnets on the mounting bracket. Make sure that the alignment tab on the back of the display panel sits in the notch on the bottom of the bracket.

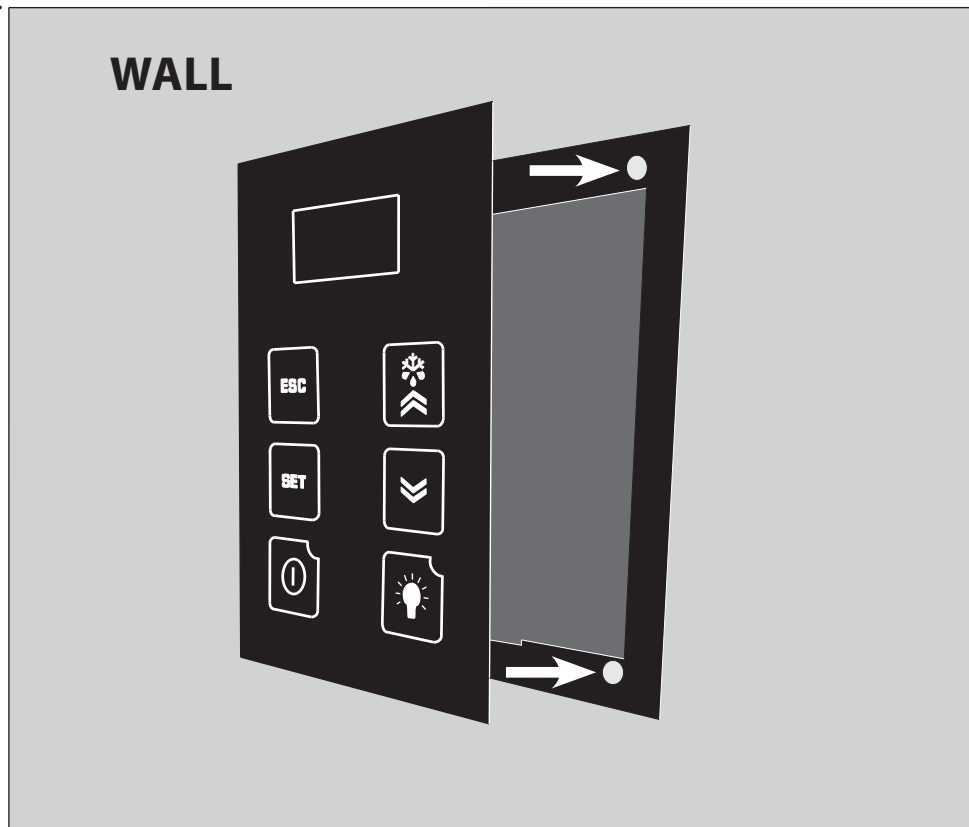

QUANTUM EVAPORATOR WIRING DIAGRAM -KDT

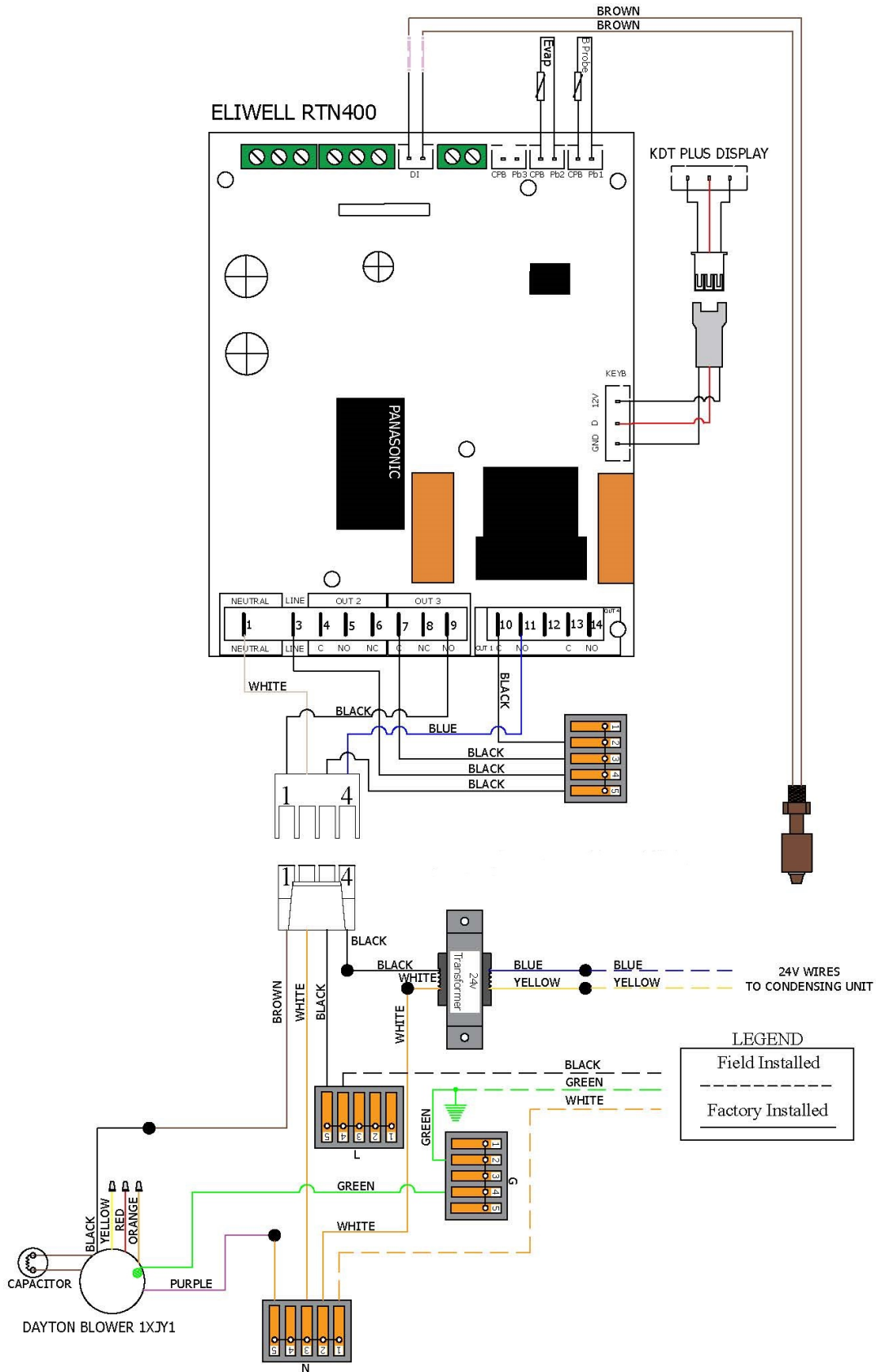

QUANTUM EVAPORATOR WIRING DIAGRAM -24V

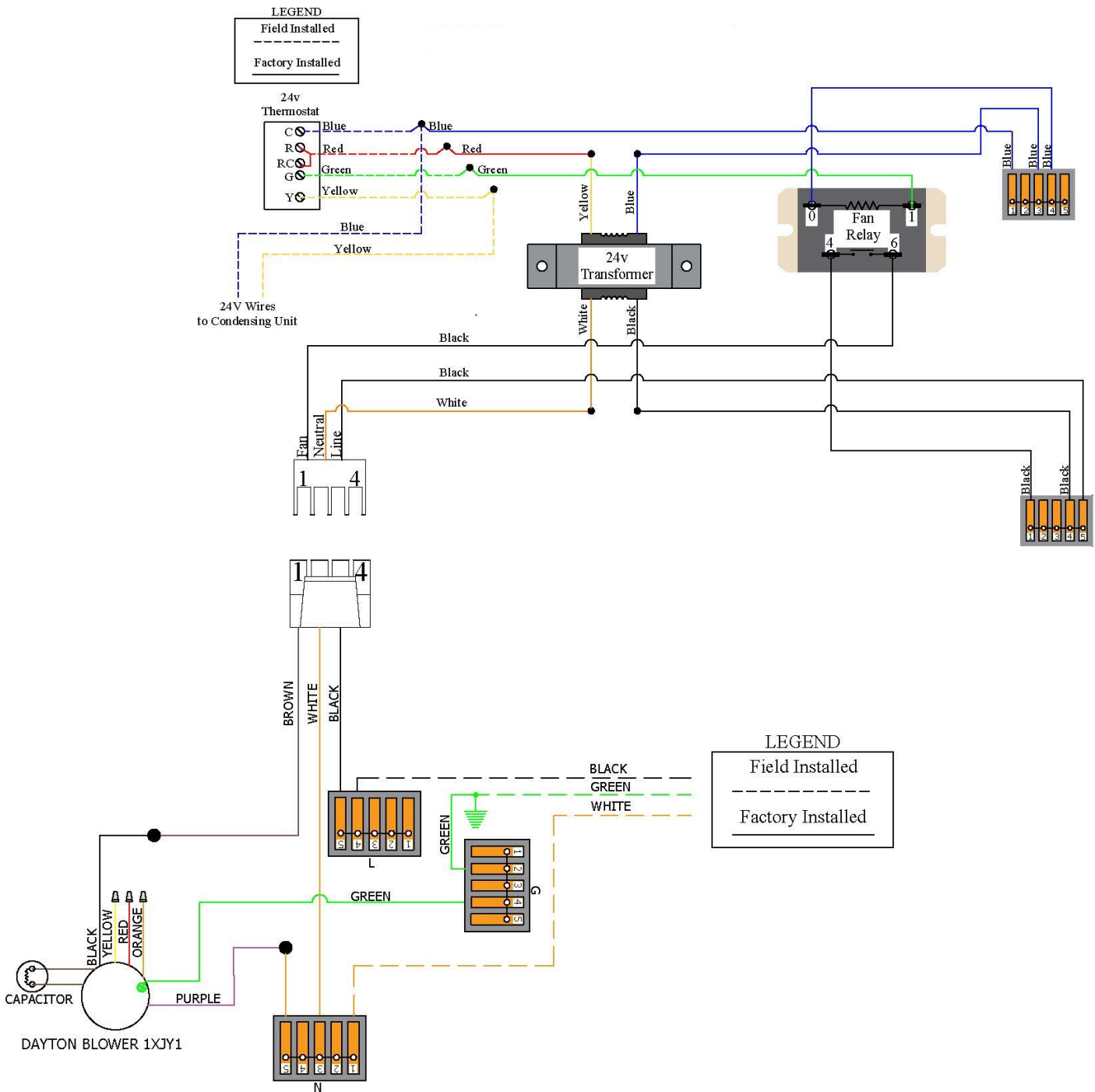

LINE SET PIPING DIAGRAMS

These are two suggested examples for running the line set from the coil to the condensing unit. Example 1 is specifically applicable when the system is installed with the condensing unit below or leveled to the coil. Example 2 is applicable when the system is installed with the condensing unit at a higher elevation than the coil.

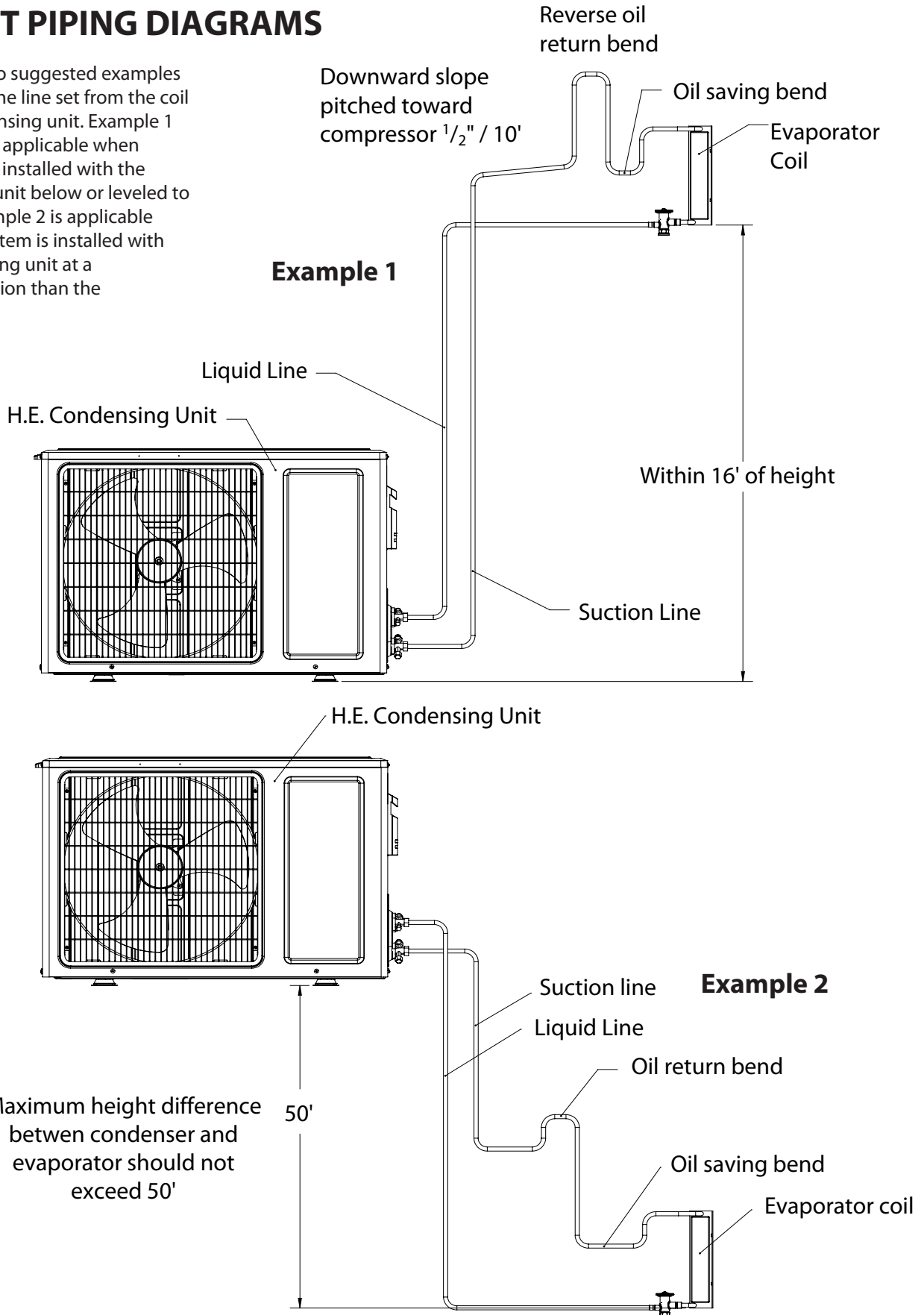

PREPARING THE CONDENSING UNIT

Electrical Needs

The unit requires a dedicated 220V, 15-amp circuit.

The unit draws a large inrush current for about 1 second the instant the compressor starts. With a dedicated circuit and circuit breaker, the condensing unit will have sufficient power for effective operation. The compressor is controlled by a contactor relay mounted to the condensing unit. 18-5 thermostat (communication line) wire must be ran from the evaporator unit to the condensing unit which energizes the contactor and allows the condensing unit to operate.

- ↳ Ensure the voltage supplied matches the rating specified on the unit spec label.
- ↳ Provide a non-GFI dedicated circuit and an appropriate outlet for the condenser unit.
- ↳ Provide a dedicated circuit and circuit breaker for the condensing unit.
- ↳ Provide a weatherproof disconnect for the condensing unit if it is located outside.

Power surges and spikes can damage sensitive electrical equipment. It is recommended that you plug the unit into a surge protector or power conditioner in order to protect your system. As outlined in our terms and conditions, power surges and spikes are not covered under warranty.

WE RECOMMEND THAT YOU DO NOT USE A GROUND FAULT INTERRUPTER (GFI) WITH THIS PRODUCT.

In case the system should lose power, check the home/main circuit breaker. If the system does not respond properly, refer to the Troubleshooting Guide.

Communication Cable Operation

Our H.E. split systems operate like traditional air conditioners where there is wiring between the condensing unit and the evaporator unit.

Our H.E. Condensing Unit systems do not utilize a solenoid valve or low-pressure switch, which allows the system to run like a residential HVAC system. A 24V communication cable must be ran between the condensing unit and the evaporator unit. When the thermostat calls for cooling, a 24V signal is sent from the evaporator air handler unit to the contactor located on the outdoor cassette condensing unit via the 24V communication cable. Once the contactor is energized, power is then delivered to the compressor and the system begins to operate.

When the cellar reaches the desired temperature and the thermostat is satisfied, the contactor is de-energized, and the compressor shuts off.

CONDENSING UNIT WIRING

1. Locate or install an electrical disconnect box near the outdoor condensing unit per electrical code.
2. Remove electrical cover plate from unit.
3. Connect wiring for: 24V contactor (communication cable), L1, L2, and Ground as identified by terminal block label.
4. Leave the circuit breaker off or remove disconnect until unit is ready to charge.

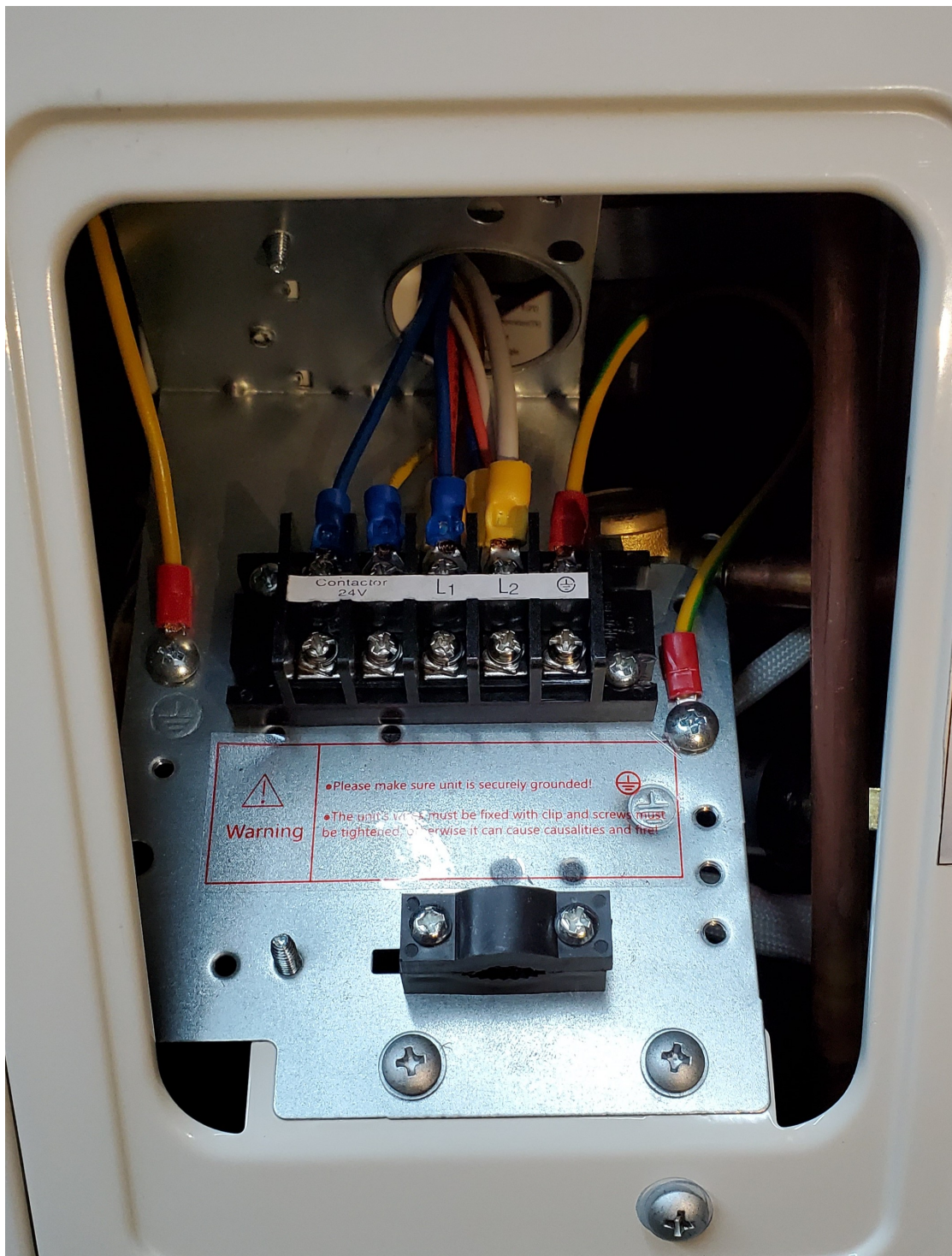

INSTALLING THE CONDENSING UNIT

Step 1: Select installation location

Before installing the outdoor unit, you must choose an appropriate location. The following are standards that will help you choose an appropriate location for the unit.

Proper installation locations meet the following standards:

- Meets all suggested spatial requirements according to diagram
- Good air circulation and ventilation
- Firm and solid—the location can support the unit, is level, and will not vibrate
- Protected from prolonged periods of direct sunlight or rain
- Condensing unit is suggested to be mounted on concrete pad. Wall mounting is optional but will cause excess vibration.

DO NOT install unit in the following locations:

- Near an obstacle that will block air inlets and outlets
- Near a public street, crowded areas, or where noise from the unit will disturb others
- Near animals or plants that will be harmed by hot air discharge
- Near any source of combustible gas
- In a location that is exposed to large amounts of dust
- In a location exposed to an excessive amount of salty air
- In a closet or small room

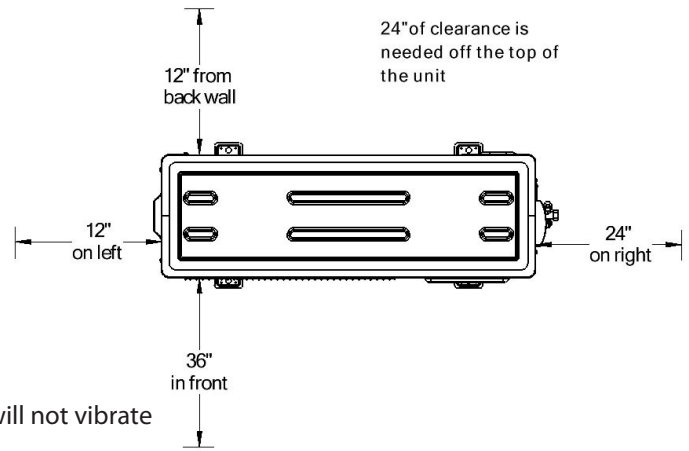

Special Considerations For Cold Weather And Other Outdoor Conditions

If the unit is exposed to heavy wind:

Install unit so that air outlet fan is at a 90° angle to the direction of the wind. If needed, build a barrier in front of the unit to protect it from extremely heavy winds.

If the unit is frequently exposed to heavy rain or snow:

Build a shelter above the unit to protect it from the rain or snow. Be careful not to obstruct air flow around the unit. Unit should be elevated to prevent build up of debris and snow in front of fan.

Step 2: Anchor outdoor unit

The outdoor unit can be anchored to the ground or to a wall-mounted bracket.

Unit Mounting Dimensions

The following is a list of different outdoor unit sizes and the distance between their mounting feet. Prepare the installation base of the unit according to the dimension

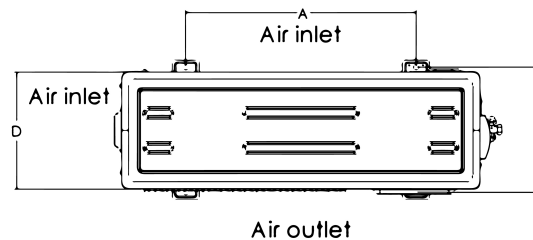
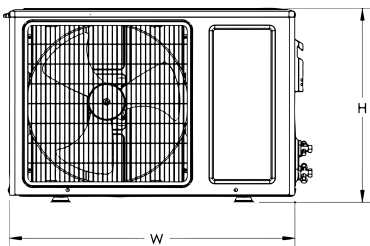

Outdoor Unit Dimensions (in.)	Mounting Dimensions	
	Distance A (in.)	Distance B (in.)
31.18"L x 10.75"D x 21.18"H	19.72"	10.71"

INSTALLING THE CONDENSING UNIT(CONTINUED)

If you will install the unit on the ground or on a concrete mounting platform, do the following:

1. Mark the positions for four expansion bolt based on dimensions in the Unit Mounting Dimensions chart.
2. Pre-drill holes for expansion bolts.
3. Clean concrete dust away from holes.
4. Place a nut on the end of each expansion bolt.
5. Hammer expansion bolts into the pre-drilled holes.
6. Remove the nuts from expansion bolts, and place outdoor unit on bolts.
7. Put washer on each expansion bolt, then replace the nuts.
8. Using a wrench, tighten each nut until snug.

If you will install the unit on a wall-mounted bracket , do the following:

1. Mark the position of bracket holes based on dimensions in the Unit Mounting Dimension chart.
2. Pre-drill the holes for the expansion bolts.
3. Clean dust and debris away from holes.
4. Place a washer and nut on the end of each expansion bolt.
5. Thread expansion bolts through holes in mounting brackets, put mounting brackets in position, and hammer expansion bolts into the wall.
6. Check that the mounting brackets are level.
7. Carefully lift unit and place its mounting feet on brackets.
8. Bolt the unit firmly to the brackets.

Step 4: Connect signal and power cables

The outside unit's terminal block is protected by an electrical wiring cover on the side of the unit. Remove the cover and wire according to diagram above and visual instructions below.

Step 5: Connect line set to condensing unit

- 1.Using a crescent wrench, grip the body of the valve. Do not grip the nut that seals the service valve.
- 2.While firmly gripping the body of the valves, use a torque wrench to tighten the flare nut according to the correct torque values.
- 3.Loosen the flaring nut slightly, then tighter again.
- 4.Repeat steps for the remaining pipe.

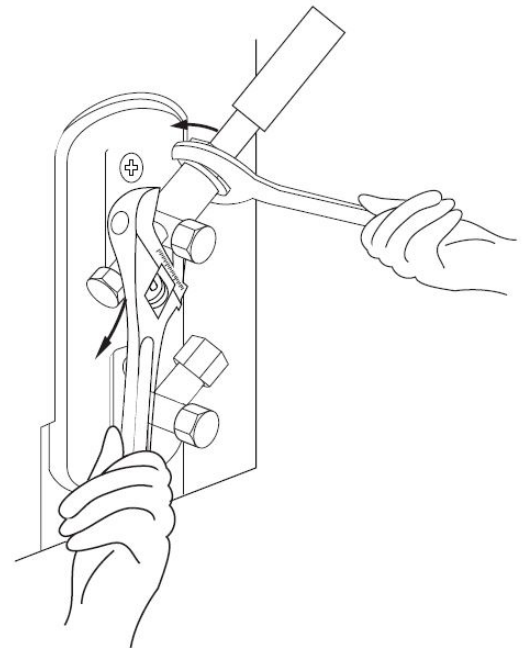

TORQUE REQUIREMENTS

Outer Diameter of Pipe (in.)	Tightening Torque (lb•ft)
Ø 1/4"	11lb•ft
Ø 3/8"	18.4lb•ft
Ø 1/2"	25.8lb•ft
Ø 5/8"	33.19lb•ft
Ø 3/4"	47.94lb•ft

INSTALLING THE CONDENSING UNIT (continued)

Quantum SS9000/ SS12000	Line Set Length	<25ft	26-50ft	50-100ft
	Suction Line	Horizontal Tubing	5/8"	
Liquid Line	Vertical Rise	5/8"		
	Horizontal Tubing	3/8"		
	Vertical Rise	3/8"		

Line set piping size is determined by the unit size and the line set length. Determine the length before selecting the size. For the vertical rise on the suction and liquid lines refer to the line set piping examples previously shown. When the condensing unit is mounted above the evaporator unit it is recommended that the suction line needs to have oil saving bends placed every 15'.

Pressure Test

After the line set has been connected securely to the evaporator and condensing unit, remove valve stem caps from low pressure (suction) and high pressure (liquid) valves on condensing unit. If desired, remove (schradler) valve cores from valves using valve core removal tool. Ensure service valve stems are in the back-seated position. If valve cores have been removed, they should be reinstalled in valves after pressure testing, vacuum, and charging procedures are complete.

Connect charge hoses of the manifold gauge to the service ports on the outdoor unit's low pressure and high pressure valves. Leave gauge manifold knobs in closed position until nitrogen is ready to be admitted into the system. Connect service hose from service port on manifold to nitrogen regulator. Set nitrogen tank regulator to approximately 225 psi. Open both high side and low side gauge manifold knobs SLOWLY at the same time to admit nitrogen into the system until the gauge manifold reads 225 psi, then close gauge manifold knobs. Let pressure stand for minimum of 10 minutes. Use soapy solution to check flare connection points for leaks. If no leaks are present and pressure is maintained after 10 minutes of pressure test, proceed with evacuation process. If any leak is detected, it must be corrected before moving onto evacuation process.

Air Evacuation/ Vacuum

- Remove the nitrogen from the system
- Remove the nitrogen tank from the manifold and attach the manifold to the vacuum pump
- Install service caps on the valves.
- After confirming that there is fresh oil in the vacuum pump, connect the hose from the manifold to the pump.
- Start the pump and run it until micron gauge reads 250 microns or less.
- Once vacuum of 250 microns or less is achieved, disconnect the vacuum pump from the system.
- Remove the micron gauge from the access valve.
- Close the valves on the manifold

Liquid Line King Valve

This location is used to charge the system with liquid refrigerant and identify the high side pressure of the system.

Calculating Subcooling

To determine the subcooling of the system, calculate the difference between the **high side pressure of the system (converted to temperature)** and the **temperature of the liquid line**. The temperature of the liquid line will be taken on the exterior of the condensing unit, about 4" away from the housing.

*Saturation temp — liquid line temp

5-15°F SUBCOOLING REQUIRED FOR WARRANTY APPROVAL

INSTALLING THE CONDENSING UNIT(continued)

Charging

- The chart below provides the approximate refrigerant charge amount for initial startup based on the line set length. Please see the chart below for the initial charge amount. The installing technician may still need to add additional charge and dial in the desired subcooling to achieve optimum performance.
- Subcooling range is between 5-15°F.
 - When charging during colder ambient temperatures (below 60°F), your target will be the lower end of the subcooling range.
 - When charging during hotter ambient temperatures (above 95°F), the target will be the upper end of the subcooling range.
- Invert refrigerant tank on a scale. Purge the charging hose up to the manifold and then zero out the scale in preparation for liquid refrigerant charging.
- With the power off to the condensing unit, admit liquid refrigerant through the liquid line service valve.
- Prior to turning on condensing unit, ensure evaporator (air handler) unit is ON and controller is calling for cooling.
- Turn on the circuit breaker for the condensing unit. The compressor and condenser fan should begin to operate.
- After startup, wait a minimum of 10 minutes for system to stabilize before checking subcooling or superheat.
- Place refrigerant tank in upright position in preparation for adding vapor refrigerant (if necessary).
- Add refrigerant (in vapor form) to the low side of the system through the suction line service port if necessary to achieve recommended subcooling.
- Check the superheat at suction service valve on the condensing unit.
- Adjust the TXV until the superheat is between 10-25°F at the service valve.
- After recommended superheat and subcooling is achieved, place the service valve stems in the back-seat position (all the way out counter-clockwise) and reinstall the Schrader valve cores. Once hoses are disconnected, reinstall all caps on service valves

Approximate Initial Charge Chart

Line Set	Charge Total
10' Line Set	4.62lbs
20' Line Set	5.00 lbs
30' Line Set	5.37 lbs
40' Line Set	5.75 lbs
50' Line Set	6.12 lbs
60' Line Set	6.50 lbs
70' Line Set	6.87 lbs
80' Line Set	7.25 lbs
90' Line Set	7.62 lbs
100' Line Set	8.00 lbs

TXV Adjustments

- A. System ships with TXV preset for 50ft.
- B. A TXV adjustment may be necessary based on ambient temperatures in the cellar and at the condensing unit.
- C. Adjust the TXV until the total superheat measured at the suction line service valve is 10-25°F.
 - i. During colder ambient temperatures (below 60°F), the target will be the lower end of the superheat range.
 - ii. During hotter ambient temperatures (above 95°F) the target will be the upper end of the superheat range.

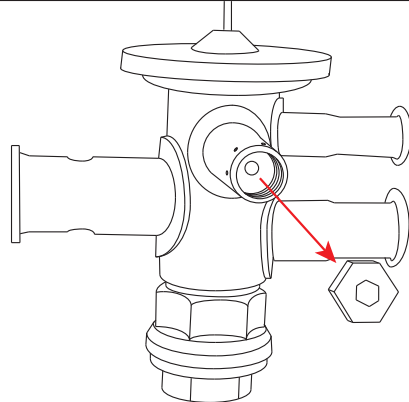
<p style="text-align: center;">TXV</p> <p>The TXV is preadjusted at the factory. If the superheat is not within 10-25° at the service valve, the TXV will need to be adjusted.</p> <p style="text-align: center;">ADJUSTING THE TXV</p> <p>Use a 5/32" hex key to remove the cap from the TXV superheat adjustment port. With the cap removed, insert the hex key into the superheat adjustment port. Increase superheat by turning the hex key clockwise. Decrease superheat by turning the hex key counterclockwise.</p>	
--	--

INSTALLING THE CONDENSING UNIT(continued)

Finalizing the Installation

- Confirm the entire suction line from the evaporator unit to the condensing unit is insulated using cellular insulation or equivalent. Seal all seams with Armaflex 520 Foam Insulation Adhesive or equivalent.
- Confirm that the control is displaying the correct temperature and that no alarms are present.

Approximate Operating Pressures (Cellar temperature 55°F)

Temp.	Low Side PSI	High Side PSI
60°F	30-35 PSIG	82-87 PSIG
75°F	32-37 PSIG	110-115 PSIG
85°F	33-38 PSIG	130-135 PSIG
95°F	34-39 PSIG	156-161 PSIG

SYSTEM OPERATION-KDT

Initial Start-Up

When the unit is plugged in and power is sent to the controller, a beep will sound, confirming that the controller is getting power. All LEDs on the display will blink three times. Three dashes will then appear on the screen. All display LEDs will then blink three times. Once the controller has gone through the initial startup process, and all LEDs have cycled, the home screen will be displayed.

Setpoint

The setpoint is preset at the factory to 55°F. It can be adjusted by the customer between 50–70°F in one-degree increments.

Indoor Fan Operation

The indoor fan will run when the controller is calling for cooling and turn off once the cooling cycle has ended. During the cooling cycle, the system will remove some relative humidity from the cellar. Some of the humidity that was removed can be reintroduced into the cellar by adjusting the “fan on” and “fan off” functions. (The cooling system is not equipped with a humidifier and does not add humidity.)

The FOF cycle should be shortened first. This will reduce the amount of time that the fan remains on following a cooling cycle. When the unit has completed a cooling cycle, the compressor and the condenser fan will turn on, but the indoor fan will continue to run for whatever length of time the customer has set. The Non function may then be lengthened to allow the fan to run longer and reintroduce moisture from the evaporator coil back into the wine cellar.

For more information about fan settings, refer to the User Menu on page .

Anti Short Cycle

The Anti-Short Cycle ensures that the unit will remain off for a period of five minutes after the unit has reached the setpoint, thereby reducing nuisance tripping of fuse or circuit breaker and allowing the pressure in the refrigeration system to equalize prior to starting the compressor.

Once the contactor relay is de-energized, the controller must wait five minutes before re-energizing the relay. This prevents the compressor from repeatedly turning off and on. If the unit is calling for cooling during this time, the compressor icon will blink, indicating that cooling is needed but the controller is waiting for the Anti-Short Cycle

Anti Frost Cycle

When the evaporator probe senses a temperature of 26°F for a duration of one minute, an Anti-Frost Cycle will be initiated. This will shut down the compressor, allowing the evaporator fan to run and melt any frost accumulation on the coil. While the Anti-Frost Cycle is running, “dEF” will be displayed on the screen.

The compressor will remain off until the evaporator coil reaches 40°F, or for a maximum of one hour. The unit will then return to normal operation.

Operation in Low Ambient Temperatures

The condensing unit comes equipped with a fan cycle switch, which controls the condenser fan operation to maintain optimal system pressures. During cold ambient temperatures when the high side pressure falls below 75 psi, the fan cycle switch will open and the condenser fan will be shut off to maintain minimum head pressure. Once the pressure reaches 110 psi, the fan cycle switch will close and allow the condenser fan to continue operation.

Digital Display

The display is designed to give the user the ability to adjust the setpoint, Fon/FOF parameters, and other settings. (See User Menu for more details.) The bottle probe temperature is displayed by default. “dEF” will be displayed during an Anti-Frost Cycle. The bottle probe and evaporator probe temperatures can be accessed by pushing the SET button and scrolling through “Pb1” (bottle probe) and “Pb2” (evaporator probe). The light button may be used as an unlock button.

Safety Features In the event of a faulty bottle probe, the compressor will cycle off for 10 minutes and on for 40 minutes. “E1” will be displayed on the screen.

Alarms

See “Alarm Codes” in the Controller Functions chart.

SYSTEM OPERATION-24V

Initial Start-Up

Set the thermostat to COOL and fan switch to AUTO. Lower the setpoint to the desired cellar temperature. (A temperature of 55°F is the recommended setpoint.) See thermostat instructions for details.

Indoor Fan Operation





If the fan switch on the thermostat is in the AUTO position, it will run only during the cooling cycle. If the fan switch on the thermostat is in the ON position, the fan will continuously run until the switch is set back to the AUTO position.

Anti Short Cycle

Most thermostats have a safety feature that will prevent the condensing unit from cycling on and off within a short period of time. During the anti-short cycle, the condensing unit will typically remain off for 5-7 minutes. See thermostat instructions for details.

Operation in Low Ambient Temperatures

The condensing unit comes equipped with a fan cycle switch, which controls the condenser fan operation to maintain optimal system pressures. During cold ambient temperatures when the high side pressure falls below 75 psi, the fan cycle switch will open and the condenser fan will be shut off to maintain minimum head pressure. Once the pressure reaches 110 psi, the fan cycle switch will close and allow the condenser fan to continue operation.

-  Compressor is on
-  Fan is on
-  Anti-Frost Cycle running
-  Alarm is present



DISPLAY LAYOUT

Return to Previous Menu

View/Change Setpoint
Enter User Menu

Power On/Off
(hold for 5 sec)

Scroll Button
Change Setpoint

Scroll Button
Change Setpoint

Unlock Button
(hold for 1 sec)

QUANTUM SS9000 SPECIFICATIONS

Model	SS9000 H.E. Evaporator Unit (Fan Coil Unit)	H.E. Condenser (Air-Cooled Condensing Unit)
Cellar Size	3000 cu. ft. *	
BTU/h (60°F condenser air intake temperature)	10985/11361	H.E. Condenser (Air-Cooled Condensing Unit)
BTU/h (75°F condenser air intake temperature)	10711/11019	
BTU/h (85°F condenser air intake temperature)	10145/10786	
Dimensions	29.5"L x 30.9"W x 19.8"H	31.18"L x 10.75"W x 21.18"H
Refrigerant	R-134a	
Condensing Unit HP	1HP	
Voltage Rating	120V (15-amp dedicated circuit required)	220V (15-amp dedicated circuit required)
Weight (lbs)	96	64
Amps	9.37 Running Amp	LRA 20, RLA 4.25, FLA 4.89
Line Set	Liquid line 3/8" OD; Suction line 5/8" OD (less than 50 ft.), 3/4" (greater than 50 ft.)	
Drain Line	3/4" ID CPVC	
Installation	Condensing unit can be installed up to 100 line feet from the evaporator unit.	
Thermostat	KDT- Advanced digital display (50-ft. cable), liquid-temperature-measuring bottle probe (50-ft. cable), 24V - Customer supplied	
Temp. Delta	Can maintain a 55°F cellar temperature with up to 120°F condenser air intake temperature	
Warranty	Two-year limited warranty (parts and labor)	





QUANTUM SS12000 SPECIFICATIONS

Model	SS12000 H.E. Evaporator Unit (Fan Coil Unit)	H.E. Condenser (Air-Cooled Condensing Unit)
Cellar Size	3500 cu. ft.*	
BTU/h (60°F condenser air intake temperature)	12147/14576	H.E. Condenser (Air-Cooled Condensing Unit)
BTU/h (75°F condenser air intake temperature)	12187/14256	
BTU/h (85°F condenser air intake temperature)	11704/13844	
Dimensions	29.5"L x 30.9"W x 19.8"H	31.18"L x 10.75"W x 23.25"H
Refrigerant	R-134a	
Condensing Unit HP	1.5 HP	
Voltage Rating	120V (15-amp dedicated circuit required)	220V (15-amp dedicated circuit required)
Weight (lbs)	96	84
Amps	9.37 Running Amp	LRA 23.6, RLA 5.76, FLA 6.6
Line Set	Liquid line 3/8" OD; Suction line 5/8" OD (less than 50 ft.), 3/4" (greater than 50 ft.)	
Drain Line	3/4" ID CPVC	
Installation	Condensing unit can be installed up to 100 line feet from the evaporator unit.	
Thermostat	KDT- Advanced digital display (50-ft. cable), liquid-temperature-measuring bottle probe (50-ft. cable), 24V - Customer supplied	
Temp. Delta	Can maintain a 55°F cellar temperature with up to 120°F condenser air intake temperature	
Warranty	Two-year limited warranty (parts and labor)	





* Sizing the Unit to the Room

The specification chart will provide information on the unit's cooling capacity. There are circumstances in which a cellar design may require a larger unit due to preexisting design restrictions. Certain building materials such as glass, stone, or concrete may seem adequate but do not offer the insulation capacity required to maintain the optimum temperature for storing wine. We recommend purchasing a unit with a larger capacity to compensate for these design limitations. Undersized cooling units can lead to premature failure and/or prevent the system from reaching the desired set temperature. As a result, they are not covered under warranty.



CONTROLLER FUNCTIONS

Button	Normal Functions								
INITIAL STARTUP	When the unit is plugged in and power is sent to the controller, a beep will sound, confirming that the controller is getting power. All LEDs on the display will blink three times. Three dashes will then appear on the screen. All display LEDs will then blink three times. Once the controller has gone through the initial startup process, and all LEDs have cycled, the home screen will be displayed.								
UNLOCKING THE DISPLAY	Press and hold any button for one second to unlock the display. (A white LED will appear in the top left corner of the button being pressed.) A beep will sound, signifying that the display is unlocked. NOTE: The display must be unlocked before any button functions become available.								
ON/OFF 	<p>To turn the unit ON, press and hold the ON/OFF button until the red LED turns OFF.</p> <p>To turn the unit OFF, press and hold the ON/OFF button until the red LED turns ON.</p>								
UP/DOWN 	The up and down arrows are used to navigate through menus and adjust parameters such as setpoint, Fon/FOF, etc.								
SET 	<p>↪ To change the setpoint, press the SET button. When "SEt" is displayed on the screen, press the SET button once more. Use the UP and DOWN ARROW buttons in order to change the value until the desired setpoint is reached.</p> <p>↪ The SET button allows you to view the setpoint, evaporator temperature, bottle temperature, alarms, and the hidden menu.</p> <p>↪ Press the SET button once. "SEt" will be displayed. Press the UP or DOWN ARROW buttons to scroll through ALr, Pb1, or Pb2.</p> <table border="1" data-bbox="467 1161 1511 1325"> <thead> <tr> <th>Set</th> <th>Setpoint</th> </tr> </thead> <tbody> <tr> <td>ALr</td> <td>Alarm folder</td> </tr> <tr> <td>Pb1</td> <td>Liquid (bottle probe) temperature</td> </tr> <tr> <td>Pb2</td> <td>Evaporator coil temperature</td> </tr> </tbody> </table> <p>↪ Press the SET button again to view any of these values.</p> <p>↪ Hold the SET button for approximately 5 seconds to enter the User Menu. (More information about the User Menu is available on page 54.)</p> <p>↪ Other parameters in the User Menu which are not available for adjustment include: idF, rEL, and LAN.</p>	Set	Setpoint	ALr	Alarm folder	Pb1	Liquid (bottle probe) temperature	Pb2	Evaporator coil temperature
Set	Setpoint								
ALr	Alarm folder								
Pb1	Liquid (bottle probe) temperature								
Pb2	Evaporator coil temperature								
ESC 	This button confirms changes made to parameters such as the setpoint and returns you to the previous menu.								
LIGHT 	The light function is not in use. However, this button can still be used to unlock the display.								

ICON GLOSSARY

Icon	Meaning
<p>SNOWFLAKE</p> 	<p>Blinking: The unit is calling for cooling, but must wait five minutes before restarting the compressor. This five-minute delay serves as an Anti-Short Cycle for the compressor's protection.</p> <p>Constant: The unit is in cooling mode and the condensing unit is running.</p>
<p>DRIPPING SNOWFLAKE</p> 	<p>The unit is undergoing an Anti-Frost Cycle. While the Anti-Frost Cycle is running, "dEF" will be displayed on the screen. See System Operation page for further details.</p>
<p>FAN</p> 	<p>The evaporator fan is running.</p>
<p>ALARM</p> 	<p>The alarm icon is shown when the unit encounters an issue that needs attention. Alarm codes are explained on the following page. All temperature-related alarms are blocked for the first 10 hours after the unit is plugged in to allow the system to stabilize and acclimate to the new environment.</p>

ALARM CODES

Code	Cause	Solution
The following alarm codes will be displayed on the screen along with the alarm icon. 		
E1	Bottle probe is not connected	Attach bottle probe to circular connector
	Faulty bottle probe connection	Locate faulty bottle probe connection by inspecting all wiring connections between the bottle probe and the circuit board. The two-pin connector for the bottle probe should be connected to the CPB/PB1 terminal on the circuit board. If it is not connected, plug it in. If a faulty connection has been identified, correct the issue or contact customer service for further assistance. NOTE: The E1 code will not appear in the alarms menu. It will be permanently displayed on the screen.
	Defective bottle probe	Replace the bottle probe
E2	Faulty evaporator probe connection	Locate faulty evaporator probe connection by inspecting evaporator probe wire. The two-pin connector for the evaporator probe should be connected to the CPB/PB2 terminal on the circuit board. If it is not connected, plug it in.
	Defective evaporator probe	Replace the evaporator probe
E7	No communication between keypad and circuit board for 60 seconds	Verify that the display cable is connected to the keypad and the circuit board and is not damaged, frayed, or kinked. If problem persists, contact Customer Service for troubleshooting information.
E10	Clock battery is dead	Replace battery NOTE: A dead clock battery will not affect the operation of your cooling unit.
The following alarm codes will not be displayed on the home screen. However, the alarm icon will be displayed in the event of an alarm. The alarms can be viewed in the Set Menu's ALr folder. 		
EA	Unit is not draining properly	<ol style="list-style-type: none"> 1. Check to see that the unit is level; if not, level it 2. Verify that the drain line is not clogged; if so, clear obstruction 3. Ensure the float switch is not stuck in open position 4. Verify wire connection at D.I. port of circuit board
AH1	The bottle probe is sensing a temperature that is 8°F above the setpoint	<ol style="list-style-type: none"> 1. Allow time for the wine to reach the desired temperature 2. Ensure that the cellar is sealed properly 3. Verify that the bottle probe is calibrated correctly (refer to the User Menu on the following page) 4. Verify that the unit is sized correctly for the cellar
AL1	The bottle probe is sensing a temperature that is 8°F below the setpoint	<ol style="list-style-type: none"> 1. Make sure the unit is not in cooling mode (the snowflake icon will not be illuminated) 2. Add heat to the room until the wine reaches the desired temp 3. Verify that the bottle probe is calibrated correctly (refer to the User Menu on the following page)
Ad2	The Anti-Frost Cycle ended on time-out	<ol style="list-style-type: none"> 1. Check the evaporator coil for ice buildup. Unplug the unit and allow the coil to thaw before restarting. 2. Make sure the room to which the unit is exhausting is not below 60°F 3. If the unit repeatedly goes into Anti-Frost Cycles (one per minute), call Customer Service for more troubleshooting information

USER MENU

The User Menu is accessed by **pressing and holding the SET button for 3 seconds**. Use the UP and DOWN ARROW buttons to navigate to desired parameters. Press the SET button again to view these parameters. Press the UP and DOWN ARROW buttons to adjust a parameter.

The following parameters are available in the menu:

Parameter	Description
Fdc - humidity enhancement	This parameter is measured in minutes, and is preset at the factory to 1. An increase in this parameter will increase the humidity enhancement of your cellar. This parameter should not be adjusted to zero. Adjustments should be made in increments of 5, with a maximum of 15 and a minimum of 1. After making any adjustments to humidity enhancement, you should wait a minimum of 3 days before making any additional adjustments. This will allow sufficient time for the cellar to acclimate to the new setting.
FOF - "fan off"	This setting controls how long the fan stays off after the setpoint has been reached. It is preset to 15 minutes. This setting should not be adjusted, as most properly constructed wine cellars retain an ample amount of humidity during the "fan off" cycle. If, however, you wish to decrease the duration of the "fan off" cycle (in order to increase the wine cellar's relative humidity), you can adjust this setting in the User Menu.
Fon - "fan on"	The "fan on" time is preset to zero minutes. This keeps the relative humidity of the wine cellar at a stable level. If, however, you wish to raise the relative humidity of your wine cellar, you can increase the duration of the "fan on" cycle in increments of five (5, 10, or 15 minutes). After making any adjustment to the "fan on" cycle, you should wait a minimum of 3 days before making any additional adjustments. This will allow sufficient time for the cellar to acclimate to the new setting.
CA1 - bottle probe (Pb1) calibration	CA1 - bottle probe (Pb1) calibration: You may use this parameter to calibrate the bottle probe to a known temperature. This parameter can be adjusted between -12°F and 12°F. For example, if the bottle probe temperature is 58°F, and the known temperature is 55°F, you can set the CA1 parameter to -3°F to match the known temperature.
PA2 - installer menu	This menu is only accessible using a password and is not available for adjustment.
dOA - digital input	This setting determines the operation of the unit during an EA alarm. The factory setting is 2, which allows the system to continue operating during an alarm. This setting must be changed to 5 if you wish to have the system shut down during an EA alarm. 2 = activates the compressor and fans 5 = disables the compressor and fans NOTE: Setting the dOA to any number other than 2 or 5 will prevent the unit from operating properly.

WHISPERKOOL TROUBLESHOOTING GUIDE

Unit has ice forming on the evaporator	
Possible cause	Solution
There is something blocking the supply and/or return air	Remove blockage
The evaporator fan is not turning on	Call service tech to troubleshoot
The evaporator unit has not gone through its anti-frost sequence yet	Check for ice in the depth of the coil. Melt with blow drier until coil is warm to the touch. Soak up water with a towel.
If evaporator continues to ice	Observe ice formation pattern. If only partway up the coil face, the system could be low on refrigerant. If all the way up, the coil may be dirty or airflow is blocked.
Unit does not run/power up	
Possible cause	Solution
Evaporator is not plugged in	Make sure the unit is plugged into an outlet
Power switch not on	Turn unit on by pressing the power button on the display
Line voltage rating is incorrect for the system	Check voltage line to make sure there is 110V-120V
Bottle at setpoint	Lower setpoint
Thermostat not calling for cooling	Lower setpoint
Faulty thermostat or wiring	Call Customer Service at 1-800-343-9463
Cellar temperature is too warm	
Possible cause	Solution
The temperature of the room to which the unit is exhausting has exceeded 110°F	Intake temperature needs to drop below 110°F
The system is undersized for the cellar	Order correctly sized system
There is something blocking the supply and/or return air on the evaporator or condenser side of the unit	Remove airflow obstruction
Compressor is not turning on	Please contact the installing technician to troubleshoot
Compressor keeps cycling on overload	Make sure condenser fan is working and there is no airflow obstruction
Poor seal around door or other areas requiring a seal (around the unit itself, wall joints, etc.)	Make sure there are no air gaps around the door. If door seal is damaged, replace it.
Controller set too high	Lower setpoint
Evaporator coil is frosted or iced up	Observe ice formation pattern. If only partway up the coil face, evaporator could be low on refrigerant. If so, contact the installing technician to assist with troubleshooting.
System runs constantly	
Possible cause	Solution
Leaky door seal or poorly insulated cellar	Fix leaky door seal and insulate cellar

Unit leaks water	
Possible cause	Solution
Evaporator unit is not level	Evaporator unit should be level in ceiling to prevent leaking
Drain line clogged or kinked	Check drain line to make sure water can flow freely
Drain is clogged, preventing water from escaping	Remove 3/4" PVC caps on P-trap and check for blockage; if necessary, use the supplied drain line brush to clean the P-trap
Drain line does not have a downward slope	Fix drain line so there is a downward slope from the unit to the drain
Coil is iced, causing the drain pan to freeze and water to overflow	Melt ice with a blow drier and soak up with a towel
Unit runs but does not cool	
Possible cause	Solution
Lack of air flow	Make sure fan is unobstructed; evaporator coil, and condenser coil are clean and free of debris
System undersized	Call Customer Service at 1-800-343-9463
Compressor is overheating	Shut system off for an hour to allow compressor to cool. Turn back on and check for cooler airflow out. If compressor runs, check to see if evaporator coil is dirty and if so, clean it. If problem persists, contact your installing technician to assist with troubleshooting.
Evaporator fan runs but compressor does not	
Possible cause	Solution
Unit is running an Anti-Frost Cycle	(1) If the system is maintaining the correct cellar temperature and there is a dripping snowflake icon illuminated on the control, the system is going through an Anti-Frost Cycle. No action is required. (2) If the system is not maintaining the correct cellar temperature, the evaporator coil may be dirty. (3) Call installing technician to troubleshoot, as the system may be low on refrigerant or require an adjustment to the TXV.
Compressor and/or starting components faulty	Contact installing technician to troubleshoot
System may be performing the WHM function	Allow cooling system to revert back to cooling mode
Compressor may have overheated	Shut system off for an hour to allow compressor to cool. Turn back on and check for cooler airflow out. If compressor runs, check to see if evaporator coil is dirty and if so, clean it. If problem persists, contact your installing technician to assist with troubleshooting.
Compressor runs but evaporator fan does not	
Possible cause	Solution
Faulty fan motor	Contact installing technician to troubleshoot
Faulty controller	Contact installing technician to troubleshoot
Compressor short cycles	
Possible cause	Solution
Evaporator fan blows on bottle probe	Move bottle probe to a more central location
System low on refrigerant charge	Contact installing technician to troubleshoot
Condensing fan motor/capacitor faulty	Contact installing technician to troubleshoot
Compressor and/or starting components faulty	Contact installing technician to troubleshoot
Humidity in cellar too low	
Possible cause	Solution
Not enough moisture	Install humidifier or decorative fountain in wine cellar

MAINTENANCE SCHEDULE

Monthly	<ol style="list-style-type: none"> 1. Check for debris surrounding condensing unit (i.e. leaves, branches, trash, etc.); remove all obstructions 2. Check for unusual noise or vibration 3. Check the drain line to see if it is above the waterline (if draining into a vessel) Inspect the external drain line for functionality. Moisture should be present inside of the drain line if system has been running. If uncertain, remove one evaporator grille and pour water into the drip pan to engage the condensate pump.
Semi - Annually	<ol style="list-style-type: none"> 1. Use a vacuum with brush attachment or compressed air to clean the evaporator coil; be careful not to crush coil fins when cleaning, clean condensing coils also 2. Remove the evaporator filter and clean with warm water 3. Ensure the condensing unit is free of debris and dust 4. Have a certified HVAC-R technician service the condensing unit and clean the condenser coil
Annually	<ol style="list-style-type: none"> 1. Inspect outdoor condenser for corrosion. 2. Check wiring connections and integrity of cords 3. Blow out drain line with air to clear any debris or buildup
Quarterly	<p>Clean out drip pan inside evaporator.</p> <ol style="list-style-type: none"> 1. Use a 5/16" nut driver to remove screws from evaporator panel and detach the panel. 2. Clean inside pan with soap & water using a sponge. 3. Test function of the drain pan. Introduce water into the pan and verify proper flow to the exit point of the drain line. 4. Once pump function has been verified, drop Air Conditioning Pan Tablet inside of pan, then replace panel with screws.

NOTE: For ducted systems, WhisperKOOL recommends filters with a mean efficiency reporting value (MERV) of 4 or better. Filters are not included with the unit.

ADDING PAN TABS

Pan tabs kill bacteria and related odors, remove sludge and scale, and help to prevent water damage caused by condensate overflow. They are non-corrosive and easy to install. Simply remove any access panel to drop a pan tab into the drip tray every six weeks.

WARNING: Keep pan tabs out of reach of children. They contain quaternary ammonium chloride and can cause skin and eye irritation. They are harmful or fatal if ingested. Wear protective gloves when handling pan tabs. Wash thoroughly after handling. If pan tabs make contact with eyes, rinse cautiously with water for several minutes. In case of an emergency, call 1-800-255-3924 (24 hours).

CLEANING P-TRAP

To clean the P-trap, remove the 3/4" CPVC cap and run a drain line brush through the T-junction until all sludge and slime is removed. If necessary, rotate T-junction for easier access. See illustration below for details.

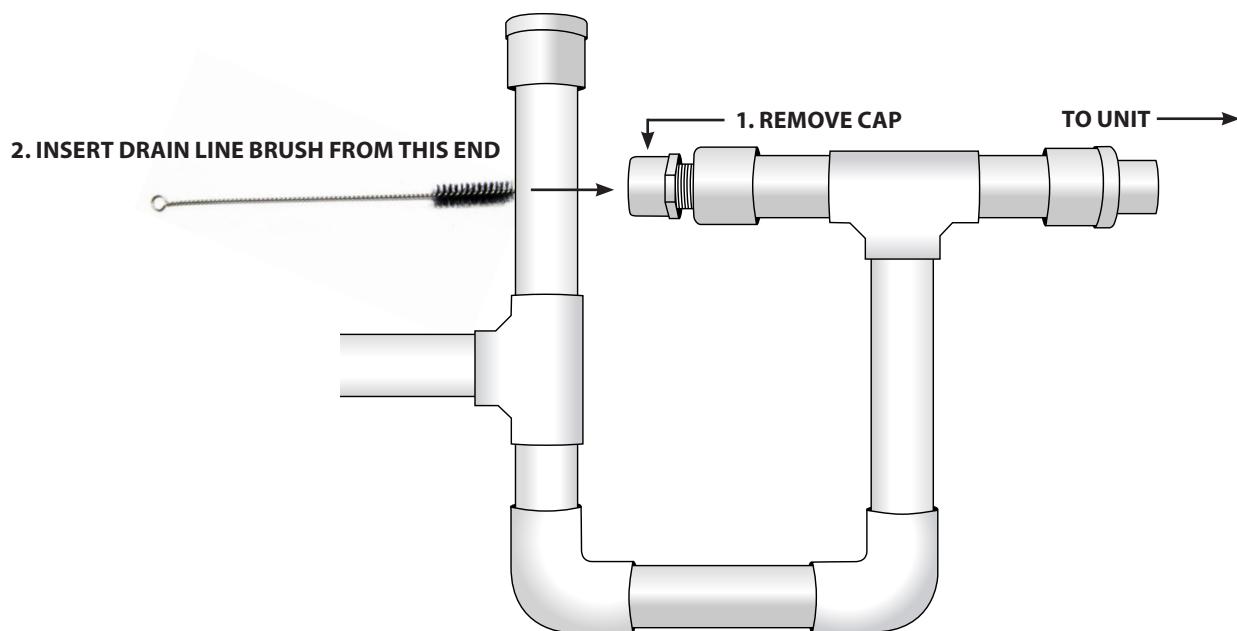

TECHNICAL ASSISTANCE

WhisperKOOL Customer Service is available Monday through Friday from 6:00 a.m. to 4:00 p.m. Pacific Standard Time.

The appointed customer service representative will be able to assist you with your questions and warranty information more effectively if you provide them with the following:

- ☞ The model and serial number of your WhisperKOOL systems.
- ☞ Location of unit and installation details, such as ventilation, ducting, construction of your wine cellar, and room size.
- ☞ Photos of the cellar and installation location may be needed.

Contact WhisperKOOL Customer Service

1738 E. Alpine Ave

Stockton, CA 95205

www.whisperkool.com

E-mail: support@whisperkool.com

Phone: 209-466-9463

US Toll Free: 1-800-343-9463

Fax: 209-466-4606

WhisperKOOL Product Terms and Conditions
Including Product Limited Warranty And Product Installation Requirements
For WhisperKOOL Split System Series

ATTENTION: PLEASE READ THESE TERMS OF USE CAREFULLY BEFORE INSTALLING YOUR WHISPERKOOL COOLING SYSTEM. INSTALLING YOUR WHISPERKOOL COOLING SYSTEM INDICATES THAT YOU ACCEPT AND AGREE TO EACH OF THE TERMS AND CONDITIONS SET FORTH HEREIN ("TERMS OF USE"). IF YOU DO NOT ACCEPT THESE TERMS OF USE, YOU RISK VOIDING YOUR WARRANTY AND ASSUMING ADDITIONAL REPAIR AND REPLACEMENT COSTS.

1. Purchase of a WhisperKOOL Cooling System assumes that the Purchaser ("End User") fully accepts and agrees to the Terms and Conditions set forth in this document. The Terms and Conditions of Sale and Owner's Manual are shipped with each unit and, if another copy is needed, replacement copies can be downloaded from the company website (whisperkool.com) or by contacting WhisperKOOL directly for a new copy. WhisperKOOL reserves the right, in its sole discretion, to change its Terms and Conditions at any time, for any reason, without notice.

2. WhisperKOOL Product Installation and Limited Warranty

- A. Purchaser of the product must arrange for the product to be installed by a certified HVAC/R technician in accordance with procedures set forth by WhisperKOOL and described in the WhisperKOOL Owner's Manual.
- B. The HVAC/R technician installing the product must complete the designated portion of the Split Startup Checklist and provide licensing or certification identification number information to assist in the warranty registration process.
- C. Purchaser must return the completed Split Startup Checklist to WhisperKOOL within thirty (30) days of installation of Product. The Split Startup Checklist must be approved by WhisperKOOL to activate the Limited Warranty. If the Split Startup Checklist is approved, Purchaser will be sent activation approval documents and will start receiving the benefits of the Limited Warranty throughout the warranty period. If the Split Startup Checklist is incomplete, Purchaser will be informed they have five days to complete the Split Startup Checklist and re-submit to WhisperKOOL. The Split Startup Checklist will be reviewed again, and if denied, Purchaser will be informed that they have 10 business days for corrective action. Failure to register the Product may result in loss of warranty.
- D. Purchaser is responsible for the full costs of installation and any additional parts required for the proper and complete installation of the product.
- E. For Split Systems returned to WhisperKOOL in accordance with the terms and conditions of the Limited Warranty, WhisperKOOL warrants against defects in material and workmanship as follows:
 - 1. LABOR** — For a period of two (2) years commencing on the date of purchase, WhisperKOOL will, at its option and discretion, reimburse up to \$250 to the End User for cost incurred for servicing, repairing, removing or installing warranty parts. Invoice for service must be forwarded to WhisperKOOL for assessment and processing. The Split System warranty is invalid if there is attempted repair by anyone other than an HVAC/R technician approved by WhisperKOOL to service the Product.
 - 2. PARTS** — For a period of two (2) years commencing on the date of purchase, WhisperKOOL will supply, at no charge, new or rebuilt replacement parts in exchange for defective parts. Replacement parts are warranted only for the remainder of the original warranty period.
 - 3. FREIGHT** — For a period of two (2) years commencing on the date of purchase, if after WhisperKOOL approved evaluation the original Product failure is determined to be the cause of a manufacturers defect, and not the cause of an installation error or other cause, WhisperKOOL will cover at its option, freight for the replacement parts or Product.

The following part or cause of failure is not the responsibility of WhisperKOOL:

- Improper voltage supply
- Line set with screw connectors (high end and low end)
- Leaks found at the braze points when performing pressure check
- Unit that has been charged incorrectly
- Incorrect tubing diameter used on line set
- A unit that has been wired incorrectly
- Valve stem on condenser side
- Improper installation of P-Trap
- Lack of P-Trap (if required)
- Condensers that are installed outdoors or in elements that would affect operation without proper cover or housing. (Housing is available from manufacturer).

Product Warranty Limitations and Exclusions

1. This limited warranty does not cover cosmetic damage caused during installation, damage due to acts of God, commercial use, accident, misuse, abuse, negligence, or modification to any part of the Product. Delivery and installation of the Product, any additional parts required, as well as removal of the Product if warranty work is required, are all at the sole cost, risk and obligation of the End User.
2. This limited warranty does not cover damage due to improper installation or operation or lack of proper maintenance of the Product, connection of the Product to improper voltage supply, or attempted repair of the Product by anyone other than a technician approved by WhisperKOOL to service the Product.
3. This limited warranty does not cover any Product sold "AS IS" or "WITH ALL FAULTS."
4. Product that has been replaced during warranty period does not extend the warranty period past the original date of purchase.
5. This limited warranty is valid only in the continental United States. Sales elsewhere are excluded from this warranty.
6. Proof of purchase of the Product in the form of a bill of sale, receipted invoice or serial number, which is evidence that the Product is within the Limited Warranty Period, must be presented by the End User to WhisperKOOL in order to obtain limited warranty service.
7. This limited warranty is void if the factory applied serial number has been altered or removed from the Product.
8. This limited warranty is voided if installed in an enclosure of insufficient design that does not follow the Product installation requirements stated herein and in the owner's manual.
9. Removing the rivets from the Product's unit housing without prior authorization from WhisperKOOL voids this limited warranty.
10. The End User must first contact WhisperKOOL Customer Service by telephone (at 1-800-343-9463) prior to attempting service on any Product still under the limited warranty; else the limited warranty is voided.
11. This limited warranty does not cover Product being concealed by, but not limited to, vegetation, fabric, shelving, mud, snow, or dirt. Product must not be painted or limited warranty will be void.
12. This limited warranty does not cover exposure to corroding environments such as, but not limited to, petroleum and gasoline products, cleaning solvents, caustic pool chemicals, and marine air.
13. This limited warranty does not cover any cause not relating to Product defect.

THE REPAIR OR REPLACEMENT OF THE PRODUCT AS PROVIDED UNDER THIS LIMITED WARRANTY IS THE EXCLUSIVE REMEDY OF YOU, THE END USER, AS WELL AS ANYONE ELSE IN THE CHAIN OF TITLE OF THE PRODUCT, DOES NOT START A NEW LIMITED WARRANTY TIME PERIOD, AND IS IN LIEU OF ALL OTHER WARRANTIES (EXPRESS OR IMPLIED) WITH REGARD TO THE PRODUCT. IN NO EVENT SHALL WHISPERKOOL BE LIABLE FOR INCIDENTAL, CONSEQUENTIAL, SPECIAL OR CONTINGENT DAMAGES FOR BREACH OF ANY EXPRESS OR IMPLIED WARRANTY ON THIS PRODUCT. THE IMPLIED WARRANTIES OF MERCHANTABILITY

AND FITNESS FOR A PARTICULAR PURPOSE ARE HEREBY EXPRESSLY DISCLAIMED.

14. Some states do not allow the exclusion or limitation of incidental or consequential damages, or allow limitations on how long an implied warranty lasts, so the above limitations or exclusions may not apply to you. This limited warranty gives you specific legal rights, and you may have other rights, which vary from state to state.
15. Failure of the End User to comply with all of the Product Installation Requirements, Maintenance Requirements and End User Requirements may, at WhisperKOOL's sole discretion, void this limited warranty.
16. No one has any authority to add to or vary the limited warranty on this Product.

3. Maintenance Requirements

The End User is responsible for checking the coils on the condenser unit and vacuuming them every three months to maintain them free of debris. It is the End User's responsibility to clean off any accumulated dust, lint, or other debris from the front and rear intake grills; failure to do this on a regular basis will restrict the airflow and may affect the Product's ability to function properly. Periodically cleaning the Product's vents will help assure maximum cooling efficiency. The drain tube must also be checked and kept clean and free of debris and mold to maintain proper performance.

Mold is a natural living organism in the environment. It exists in the air in the form of microscopic spores that move in and out of buildings through doors, windows, vents, HVAC systems and anywhere else that air enters. Once it is discovered, mold must be addressed quickly and appropriately. Delayed or improper treatment of mold issues can result in costly and reoccurring repairs. If the End User suspects a mold problem, it is always best to hire a qualified and experienced mold remediation specialist.

4. Additional End User Costs And Responsibilities

Terms and conditions for replacing the Product that is being evaluated for limited warranty:

1. After evaluation by a certified HVAC/R technician and the Product is found to be irreparable in the field, contact WhisperKOOL Customer Service to arrange for replacement under the warranty guidelines. When a claim for warranty is submitted for a condenser skid, the End User must purchase a new condenser skid from WhisperKOOL at retail price. Upon installation of the new condenser skid by a certified HVAC/R Technician, the HVAC/R Technician must complete the Installation Checklist and End User must submit the Installation Checklist to WhisperKOOL Customer Service for approval. The original condenser skid must be returned within 21 days to WhisperKOOL for failure analysis. If the Installation Checklist is approved and the failure is evaluated as defective and not installation error or other reason, the End User will be refunded for the cost of the replacement skid.
2. If the Product failure is evaluated and it is determined that it is an installation error or other reason, all costs, including shipping will be the responsibility of the End User.

The following items are not covered under any warranty and are the sole responsibility of the End User:

- A. End Users should satisfy themselves that the Product they are purchasing is suitable for their particular needs and requirements, and thus no responsibility will be placed with WhisperKOOL for the End User's decisions in this regard.
- B. End Users must assure that the product is installed by a certified HVAC/R technician. Failure to do so will result in Voiding the Limited Warranty.
- C. It is the End User's responsibility to secure safe haven/storage for ANY AND ALL items that are being kept and stored in the End User's wine cellar, including any Product. WhisperKOOL takes no responsibility for the safety and preservation of the aforementioned items in the event that the environment becomes unsuitable to maintain a proper storage environment.
- D. End User is responsible for initial installation costs, including, but not limited to, labor costs and the cost of any additional parts necessary to complete the installation.
- E. End User is responsible for all costs incurred for the installation and/or removal of the Product, or any part thereof, unless such cost has been agreed by WhisperKOOL to be a warranty repair prior to the work being performed.

5. Sales and Use Tax

WhisperKOOL only collects California sales tax for orders shipped within the State of California; WhisperKOOL does not collect sales tax for orders shipped to other states. However, the Purchaser and the End User may be liable to the taxing authority in their state for sales tax and/or use tax on the Product. The Purchaser and the End User should each check with their state's taxing authority for sales and use tax regulations.

6. Customer Service and Troubleshooting

WhisperKOOL's customer service department is available to answer any questions or inquiries for End Users regarding a WhisperKOOL Product, as well as to assist in performing basic troubleshooting, Monday through Friday, from 6:00 a.m. to 4:00 p.m. PST, at telephone number 1-800-343-9463. WhisperKOOL reserves the right to have a certified, WhisperKOOL-approved, HVAC/R technician go on site and inspect the product if the initial trouble shooting warrants further investigation. WhisperKOOL Corporation is located at 1738 East Alpine Avenue, Stockton, California 95205.

7. Request for Product Evaluation and Repair Under Warranty

SPLIT SYSTEM FIELD SERVICE WARRANTY POLICY: This Policy is to clarify what falls under Warranty Service and what becomes the responsibility of the Owner. WhisperKOOL ("manufacturer") strives to provide our customers with a superior Product and we back our Product with a Two Year Limited Warranty. Please review the WhisperKOOL Product Terms and Conditions including Product Limited Warranty and Product Installation Requirements to ensure you have a complete understanding of our Policy and coverage of your Split System.

ARBITRATION: Any disputes arising out of or in connection with the installation and warranty of the Split System shall be referred to and finally resolved by a WhisperKOOL approved Independent Certified HVAC/R Technician. The evaluation of the Technician on all issues or matters of identifying the responsible party (WhisperKOOL or Installing Technician) shall be determined in a written report. This report will be made available to all concerned parties. If discovered under warranty, WhisperKOOL will assume the financial responsibility under their warranty guidelines. If the report finds the Owner's Installer as the responsible party, WhisperKOOL will provide all documentation to the customer to substantiate the findings. This will include the Invoice from the Independent Certified HVAC/R Technician and the written report of the findings. The Owner will become responsible for payment directly to WhisperKOOL for all charges incurred for repairs (labor, parts and shipping costs) on the Split System.

8. Miscellaneous Terms and Conditions

- A. Return Policy. All return inquiries must be made within thirty (30) calendar days of the original purchase of a Product and are subject to a twenty five percent (25%) restocking fee. Shipping costs are not refundable and the Purchaser is responsible for all return shipping costs (including customs fees and duties, if applicable).
- B. Security Interest. WhisperKOOL retains a security interest in each Product until payment in full.
- C. Construction and Severability. Every provision of these Terms and Conditions shall be construed, to the extent possible, so as to be valid and enforceable. If any provision of these Terms and Conditions is held by a court of competent jurisdiction to be invalid, illegal or otherwise unenforceable, such provision will, to the extent so held, be deemed severed from the contract of sale between Purchaser and WhisperKOOL, and all of the other non-severed provisions will remain in full force and effect.
- D. Governing Law/Choice of Forum. The laws of the State of California (without regard for conflicts of law) shall govern the construction and enforcement of the these Terms and Conditions of Sale (Sections 1 through 9 inclusive, including Product Limited Warranty And Product Installation Requirements), and further these Terms and Conditions of Sale shall be interpreted as through drafted jointly by WhisperKOOL and Purchaser. Any dispute will be resolved by the courts in and for the County of San Joaquin, State of California, and all parties, WhisperKOOL, Purchaser and End User, hereby irrevocably submit to the personal jurisdiction of such courts for that purpose. No waiver by WhisperKOOL of any breach or default of the contract of sale (including these Terms and Conditions of Sale) concerning a Product will be deemed to be a waiver of any preceding or subsequent breach or default.
- E. Correction of Errors and Inaccuracies. These Terms and Conditions may contain typographical errors or other errors or inaccuracies. WhisperKOOL reserves the right to correct any errors, inaccuracies or omissions, and to change or update these Terms and Conditions, at any time without prior notice.

9. Questions, Additional Information And Technical Assistance

A. Questions. If you have any questions regarding these Terms and Conditions or wish to obtain additional information, contact us via phone at 1-800-343-9463 or please send a letter via U.S. Mail to:

Customer Service
WhisperKOOL Corporation
1738 E Alpine Ave
Stockton, CA 95205
E-mail: support@whisperkool.com
Web: www.whisperkool.com

B. Technical Assistance. WhisperKOOL Customer Service is available Monday through Friday from 6:00 a.m. to 4:00 p.m. PST. The Customer Service representative will be able to assist you with your questions and warranty information more effectively if you provide them with the following:

1. The model and serial number of your WhisperKOOL UNIT.
2. The location of the system and installation details, such as ventilation, construction of your wine cellar, and room size.

WARRANTY REGISTRATION

In order to activate the warranty of your system, the verification and operational documentation must be completed by the certified refrigeration technician installing your system and submitted via mail, fax, or e-mail.

Mail to:
WhisperKOOL
ATTN: Warranty Registration
1738 E. Alpine Avenue
Stockton, CA 95205-2505
USA

Fax to:
209-466-4606

Scan and email to:
warranty@whisperkool.com

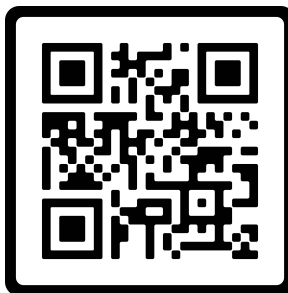

Model _____ Serial Number _____

Installed by _____ Date _____

*Whisper***KOOL**[™]

WhisperKOOL
1738 E. Alpine Ave
Stockton, CA 95205
1-800-343-9463
www.whisperkool.com